

APEX CONNECTORS

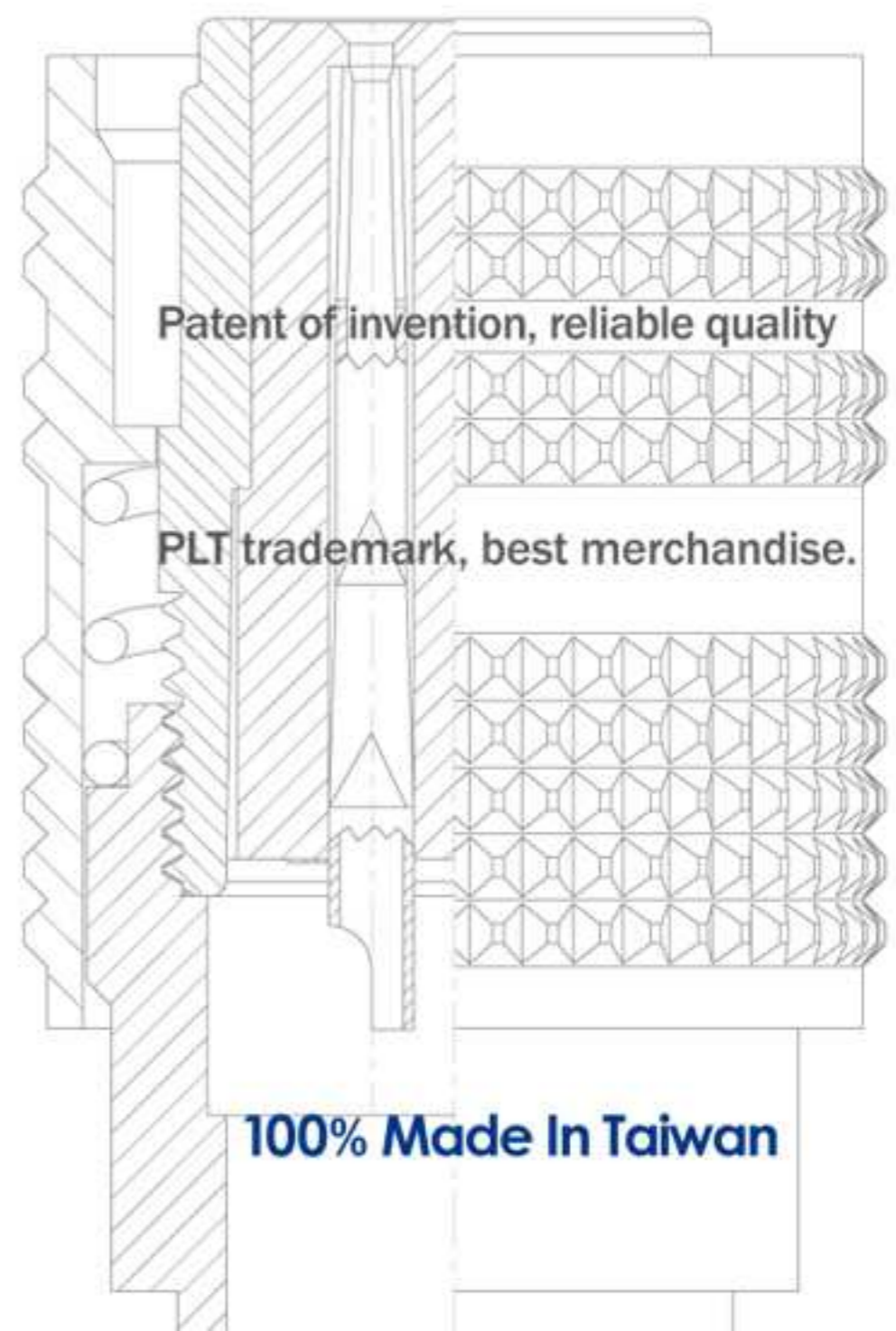

Apex connector

錫鋼精密科技
APEX PRECISION TECHNOLOGY

Since 1978

100% Made In Taiwan

APEX Enterprise and Nature Coexistence

Coexistence of human and nature is the highest enterprise principle to APEX.
All APEX's staff and operation must be based on the premise of preserving natural environment and protecting the earth.

- Manufacturing the low-pollution products
- Manufacturing without polluting the environment
- Recycle and reuse
- Contribution to protecting the earth
- Development of environmental protection

1.The product information in this catalog is for reference only.

Please request the engineering drawing for the most current and accurate design information.

2.In order to make improvements in the products,we reserve the right to make changes, updates and corrections to the information provided in this catalog at any time.

Subject to change without notice. Thank you for your understanding.



APEX 企業與自然共存

APEX 應該視(人類和地球自然環境共存)為企業最高指導的原則，
所有的APEX職員和企業的全部運作，都要以維護自然環境、保護地球為前提。

- 製造低污染的產品
- 製造處理不汙染環境
- 所有的廢棄物回收再利用
- 為保護地球環境，貢獻一份心力
- 持續環境保護發展的工作

1.本目錄記載數據僅供參考，詳細內容請參考式樣書或圖面。

2.本目錄記載內容為了改進產品如有變更，恕不另行通知敬請見諒。

APEX企業は自然と共存します

APEXはずっと<人類と地球の共存する環境>を企業最高指導の原則とし、
全てのAPEX社員及び企業の活動は全て地球環境の保護、維持を前提としております。

- 汚染の少ない製品作り
- 製造プロセスでは環境汚染を下げる
- すべての廃棄物は回収または再利用する
- 地球環境保護のため、気力を持って貢献する
- 環盡保護發展の仕事を持続する

1.本カタログ記載の数値につきましては、参考数値です。詳しい内容につきましては、仕様書、図面を参考して下さい。

2.本カタログ記載内容は、製品向上のため予告なく変更する事がありますのでご了承下さい。

Assembling Method(PLS-28) / 組合方法 1-1

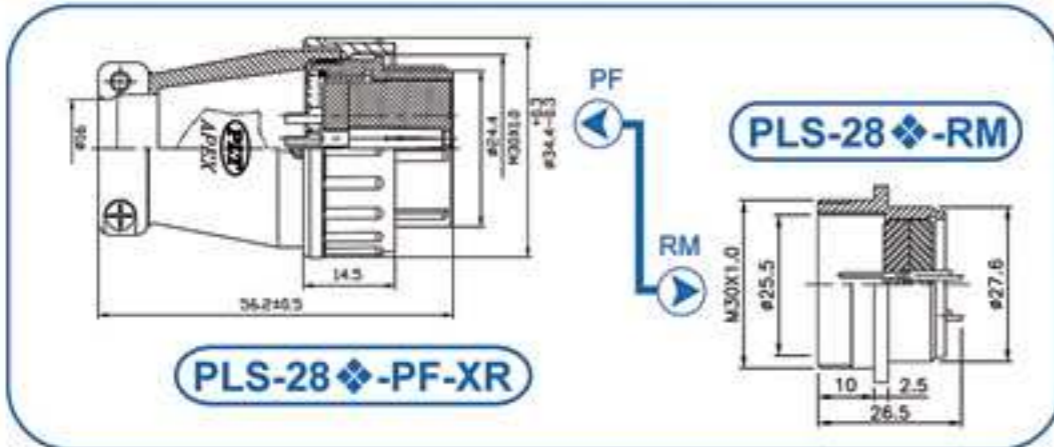

PLT Series Circular Connectors / 圓型連接器 2-1

Overview / 產品圖	Series / 系列名稱	Page/頁數
	PLT-8 Series (INPUT TYPE) (OUTPUT TYPE)	2-3
	PLT-9 Series (OUTPUT TYPE)	2-4
	PLT-1016 Series (INPUT TYPE) (OUTPUT TYPE)	2-5
	PLT-11 Series (INPUT TYPE) (OUTPUT TYPE)	2-6
	PLT-14 Series (OUTPUT TYPE)	2-7
	PLT-15 Series (INPUT TYPE)	2-8

Overview / 產品圖	Series / 系列名稱	Page/頁數
	PLT-15.5-AD-R PLT-15.5-P-R	2-9
	U-C5 PLT-16-P-R PLT-16-R-R PLT-16-LP-R Series (INPUT TYPE) Stainless Steel 不鏽鋼材質 PAT	2-10
	PLT-16-PM-R PLT-16-RF-R Series (OUTPUT TYPE)	2-11
	PLT-16-A-PM-R PLT-16-A-RF-R Series (OUTPUT TYPE)	2-12
	PLT-17 Series (INPUT TYPE) Engineering Plastic 工程塑膠	2-13
	PLT-18 Series (OUTPUT TYPE)	2-14
	IP67 PLT-18 Series (INPUT TYPE) (OUTPUT TYPE)	2-14
	PLT-19 Series (INPUT TYPE)	2-15

Contents

Overview / 產品圖	Series / 系列名稱	Page/頁數
	PLT-25 Series (INPUT TYPE)	2-16
	PLT-25 Series (OUTPUT TYPE) PLT-254E-RF-R	2-17
	PAT PLT-25A Series (INPUT TYPE) Engineering Plastic 工程塑膠 IP65	2-18
	PLT-30 Series (INPUT TYPE)	2-19
	PAT PLT-30 Series (OUTPUT TYPE) PLT-304E-RF-R PLT-307E-RF-R	2-20
	PAT PLT-30 Series - PN PLT-30 Series - RN (INPUT TYPE) 螺絲鎖附型 Screw-Lockup-Contact Model	2-21
	PLT3106A / PLT3102A Series (INPUT TYPE) IP67	2-22

Overview / 產品圖	Series / 系列名稱	Page/頁數
	PLT3106A / PLT3102A Series (INPUT TYPE) IP67	2-23
	PLT3106A / PLT3102A Series (INPUT TYPE) IP67	2-24
	PLT-32 Series (INPUT TYPE)	2-25
	PLT-40 Series (INPUT TYPE)	2-26
	PLT-40 Series (OUTPUT TYPE)	2-27
	PLT-50 Series (INPUT TYPE)	2-28
PLK Series Circular Connectors / 圓型連接器 3-1		
Overview / 產品圖	Series / 系列名稱	Page/頁數
	PLK-16 Series - RA/PA Series (INPUT TYPE)	3-3



● 備註：另有鎖側螺絲選項 Optional accessory : side screws

● 以上機種可設計防水型 Above models could be altered to waterproof types IP65 IP67 IP68

專利產品·仿冒必究

Patent of invention, all rights reserved

Overview / 產品圖	Series / 系列名稱	Page/頁數
	PLK-16 Series (INPUT TYPE)	3-4

	PLK-30 Series (OUTPUT TYPE)	3-5
--	---------------------------------------	-----

PLS Series Square Connectors / 方型連接器 4-1

Overview / 產品圖	Series / 系列名稱	Page/頁數
	PLS-20 Series (INPUT TYPE)	4-3

	PLS-20 Series (OUTPUT TYPE) PLS-203E-RF-R PLS-207E-RF-R	4-4
--	---	-----

	PLS-24 Series (INPUT TYPE)	4-5
--	--------------------------------------	-----

	PLS-24 Series (OUTPUT TYPE)	4-6
--	---------------------------------------	-----

	PLS-27 Series (OUTPUT TYPE)	4-7
--	---------------------------------------	-----

Overview / 產品圖	Series / 系列名稱	Page/頁數
	PLS-28 Series (INPUT TYPE)	4-8

	PLS-28 Series (OUTPUT TYPE) PLS-2812E-RF-R	4-9
--	---	-----

	PLS-28 Series (INPUT TYPE) Stainless Steel 不銹鋼材質	4-10
--	--	------

	PLS-35 Series (INPUT TYPE)	4-11
--	--------------------------------------	------

	PLS-35 Series (OUTPUT TYPE)	4-12
--	---------------------------------------	------

	PLS-41 Series (INPUT TYPE)	4-13
--	--------------------------------------	------

	PLS-42 Series (INPUT TYPE)	4-14
--	--------------------------------------	------

● 備註：另有鎖側螺絲選項 Optional accessory : side screws

● 以上機種可設計防水型 Above models could be altered to waterproof types



Patent of invention, all rights reserved

專利產品·仿冒必究



Contents

Complex Series / 綜合型號		5-1
Overview / 產品圖	Series / 系列名稱	Page/頁數
	PAT PLP-◆Series (INPUT TYPE) (OUTPUT TYPE)	5-2
	PAT PLP-◆Series (INPUT TYPE) (OUTPUT TYPE)	5-2
	PAT PLP-◆Series (INPUT TYPE) (OUTPUT TYPE)	5-2
	PLP-141P◆ Series	5-3
	PLP-154P◆ Series	5-4
	M-6029 Series	5-5
	PLTS-40◆Series PAT	5-6
	U-C5 PLT-16-RCaC-R PLT-16-RCa-R	2-10

Overview / 產品圖	Series / 系列名稱	Page/頁數
	防塵蓋(銅) Dust Cap(Copper) PLT-19-RCa-R	2-15
	防塵蓋(鋅) Dust Cap(Zinc) PLT-25C-RCa-R PLT-30C-RCa-R	2-16,2-17 2-19,2-20 2-21,3-5
	防塵蓋(塑膠) Dust Cap(Plastic) A-590PX A-591PX 本件增值不加價 Value-Added with the Same Price	2-16,2-17 2-19,2-20 2-21,3-5
	防塵蓋(塑膠) Dust Cap(Plastic) PLT-25A-RCa-R PLT-30A-RCa-R PAT	2-16,2-17 2-19,2-20 2-21,3-5
	防塵蓋(塑膠) Dust Cap(Plastic) A-587PX A-588PX A-589PX 本件增值不加價 Value-Added with the Same Price	4-3,4-4 4-5,4-6 4-8,4-9
	防塵蓋(鋅) Dust Cap(Zinc) PLT-32C-RCaN-R PLT-40C-RCaC-R PLT-50-RCa	2-25 2-26,2-27 2-28
	防塵蓋(鋅) Dust Cap(Zinc) PLK-16C-RCaC-R	3-4
	防塵蓋(鋅) Dust Cap(Zinc) PLS-20C-RCaC-R PLS-24C-RCaC-R PLS-28C-RCa-R	4-3,4-4 4-5,4-6 4-8,4-9
	防塵蓋(鋁) Dust Cap(Aluminum) AMS25043-24A	4-11,4-12

組裝步驟說明 Assembly Instructions 適用機種：PLT-25系列、PLT-30系列

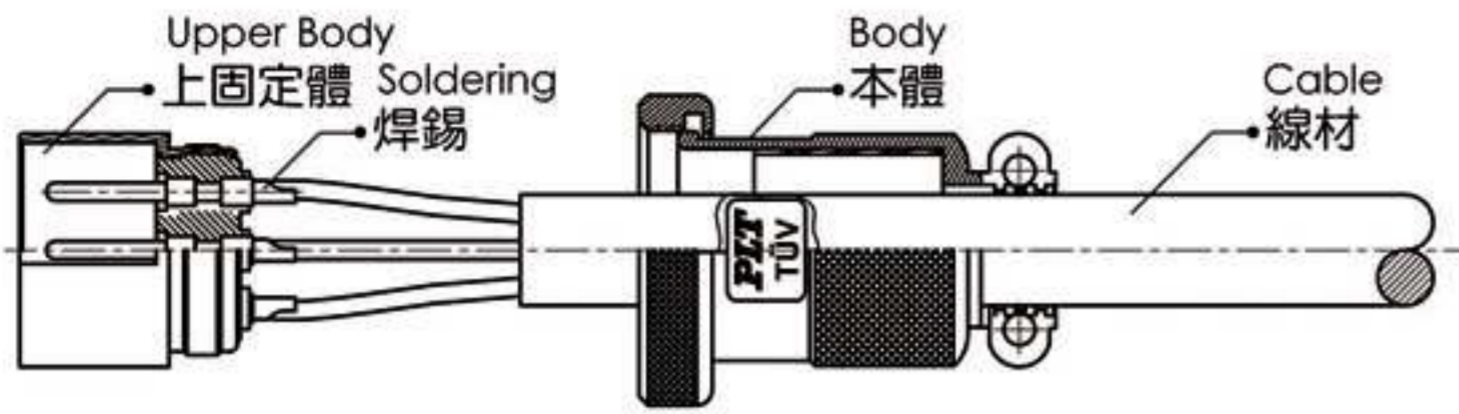

1 線材穿過本體
Cable goes through the body



2 使用夾具將接頭夾持住，線材裸線與上固定體的接觸體缺口進行焊線加工
Using the clamp to fix the connector
Doing soldering assembly between the bar wire and upper body



3 本體與上固定體對鎖，將螺紋順時針方向鎖緊（需轉動本體鎖入，非轉動接頭）
The body and the upper one are locked together. Screw clockwise and be sure to only rotate the body itself instead of the whole connector



4 半月邊壓入（與線材不能留有間隙）
Crescent-shaped clamp mounted
(The gap couldn't be allowed with the cable connected)

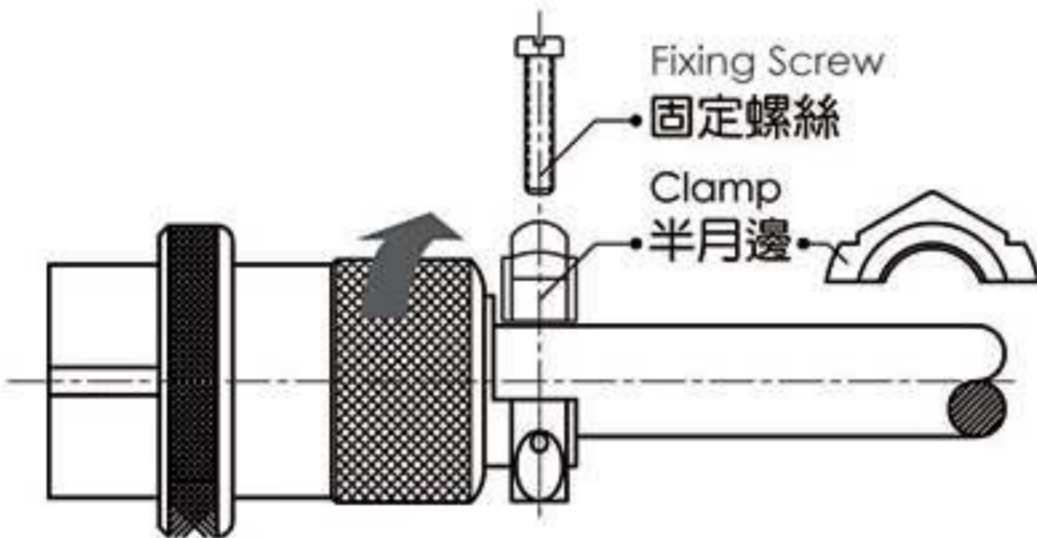

5 固定螺絲（圓頭十字 x 2支）鎖緊
With 2 screws (Round head) screwed tight



6 完成 Finish

⚠ 特別注意：拔出步驟說明 Pull-out instruction



插頭與插座要分開時，請將**1**固定帽依**3**之方向旋開，再將插頭與插座分離。

When pulling out the plug, please follow **3** screw off direction to pull out the plug and socket.

（請勿直接旋開本體，避免線材因扭轉導致斷裂）
Don't screw off the body itself in case the cable would be broken while twisting

Instruction

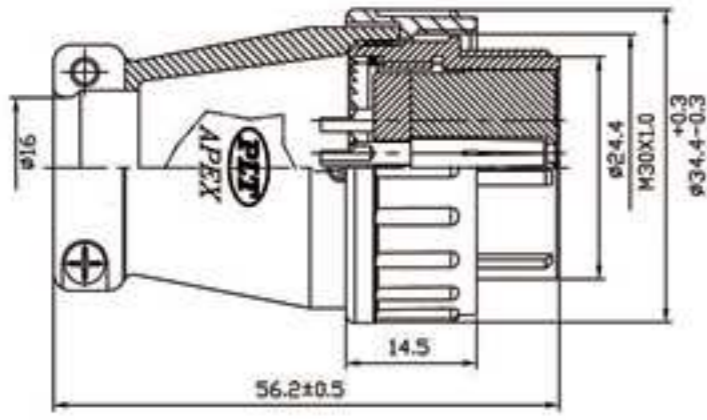

PLS-28 -PF X-R

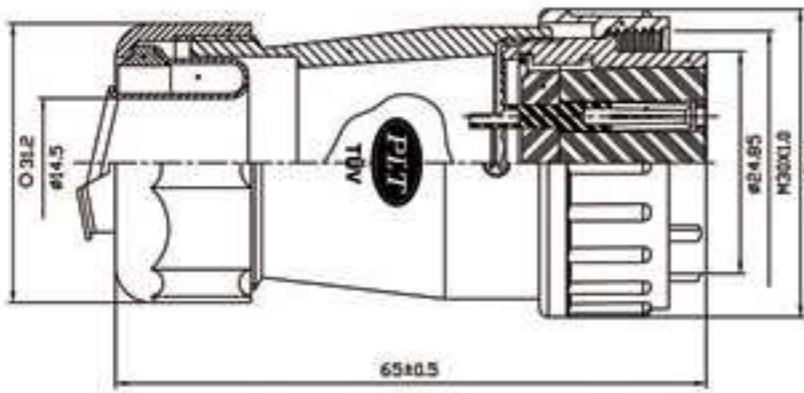

PLS-28 -GPF X-R

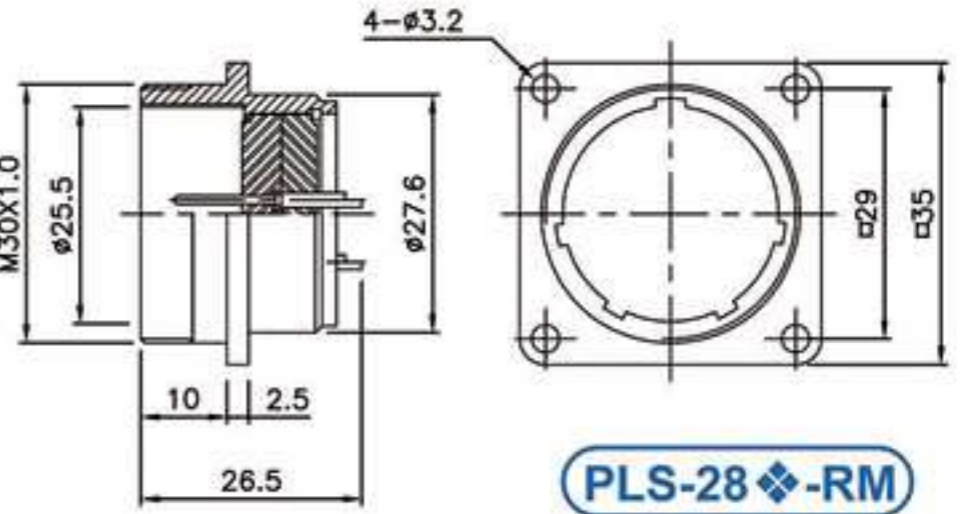
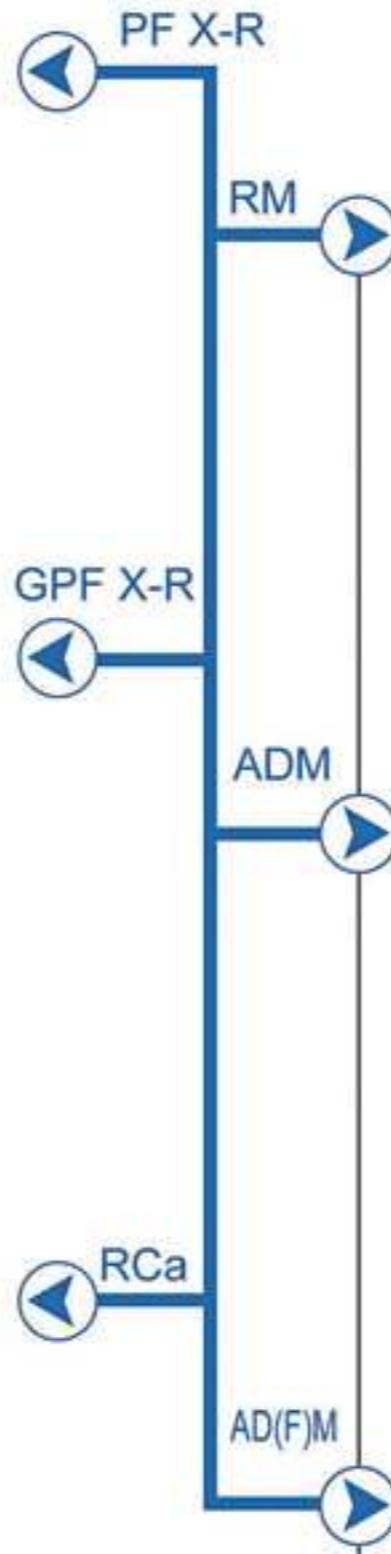

PLS-28 -RM

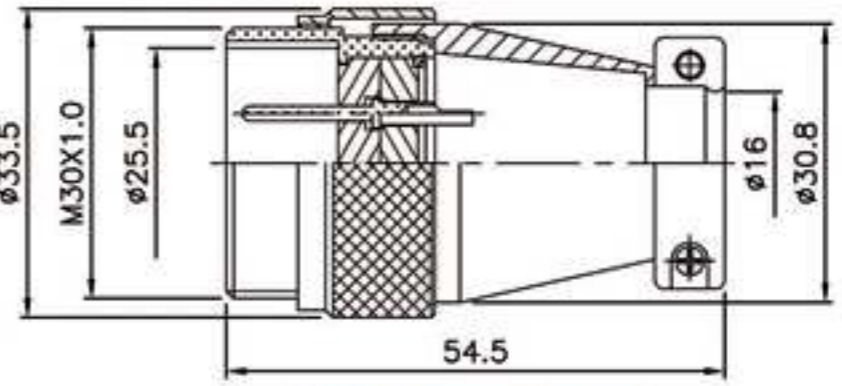

PLS-28 -ADM

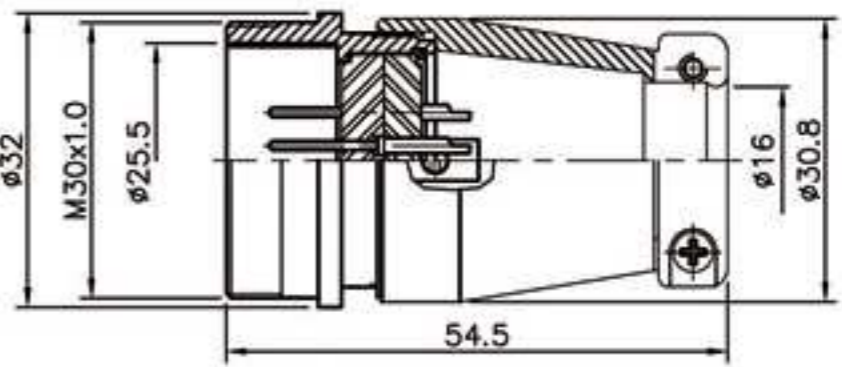

Please select the required contact no. from the below column

請從下列的欄位中選擇一個適當的接點

Nomenclature 表示方法
PLS-28 -GPF

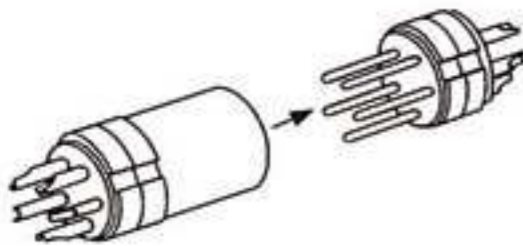

The insertion between male and female contacts.
母導梢與公導針對接

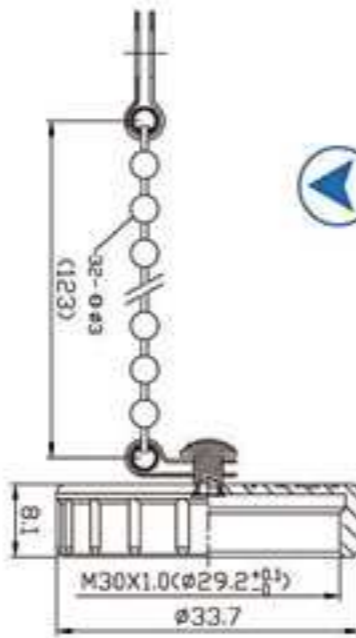

Connection 組合

In addition, when the direction of arrows are identical, the assembly may not be proceeded

此外，當箭頭的方向相同時，則無法組合

(TUV Approved)

UL : (UL Approved)

◆ No. of contacts 接點數目	12	16	17	20	26		
Contacts Configuration 接點方位							
Rated current / voltage 額定電流 / 電壓	10A 250V	5A 250V	5A 250V	5A 250V	5A 250V		
Operating voltage limit (AC.V.rms) 操作電壓限制	250	250	250	250	250		
Withstanding voltage (AC.V.rms) 1 minute 耐電壓1分鐘	1000	1000	1000	1000	1000		
Insulation resistance (MΩ MIN.) at DC 500V 絕緣阻抗	1000	1000	1000	1000	1000		
Contact resistance (mΩ MAX.) at DC 1A 接觸阻抗	5	5	5	3	3		
Solder inter diameter 焊孔內徑	1.6	1.6	1.6	1.2	1.2		



PLT-8 Series



PLT-9 Series



PLT-10 Series



PLT-11 Series



PLT-14 Series



PLT-15 Series



PLT-15.5 Series



INPUT TYPE PAT
PLT-16 Series



OUTPUT TYPE
PLT-16A Series



Engineering Plastic 工程塑膠
PLT-17 Series



PLT-18 Series



PLT-19 Series



PLT-25 Series



PAT
PLT-25A Series



PLT-30 Series



Screw-Lockup Contact Model 螺絲鎖附型
PAT
PLT-303 Series



PLT-31 Series



PLT-32 Series



PLT-40 Series



PLT-50 Series



WGP
防水電氣配管
Liquid-Tight Conduits



GP
防水防爆電氣配管
Explosionproof Liquid-Tight Conduits



CG
耐扭式電纜固定頭
Flex Protective Cable Glands



● ORDERING INFORMATION

PLT-162-P-R



P	Plug	插頭	AD	Adapter	中繼
R	Receptacle	插座	Ca	Cap	保護蓋
F	Female	導梢	RT	Rubber tube	橡膠管
M	Male	導針	GP	Conduit type	軟管式
WGP	Nylon type	尼龍管式	CG	Cable glands	迫緊頭
LP	Shape	L型90°	RL	Single thread	單牙

● MATERIAL & FINISH

Kindly instruct material & finish by below types when ordering

Description	Material	Finish
Shell/外殼、本體	<ul style="list-style-type: none"> • Stainless Steel/不鏽鋼 • Zinc Die-Casting/鋅合金壓鑄 • Aluminum alloy/鋁合金壓鑄 	<ul style="list-style-type: none"> • Chrome-plated/鍍鉻 • Gold-plated/鍍金 • Nickel-plated/鍍鎳 • Silver-plated/鍍銀
Insulator/絕緣體	<ul style="list-style-type: none"> • Bakelite/電木 • Delrin/塑鋼 • Teflon/鐵氟龍 	
Contact/接觸體	<ul style="list-style-type: none"> • Brass/銅 • Phosphor bronze/磷青銅 • Beryllium copper/鈹銅 	<ul style="list-style-type: none"> • Gold-plated/鍍金 • Nickel-plated/鍍鎳 • Silver-plated/鍍銀



Input Type / Output Type

2

PLT SERIES

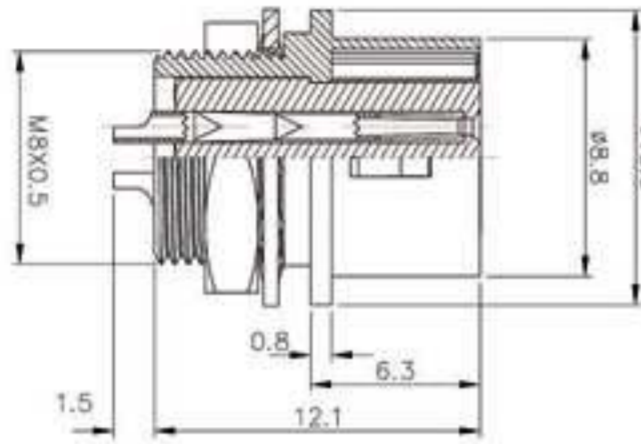

PLT-8-RF-R

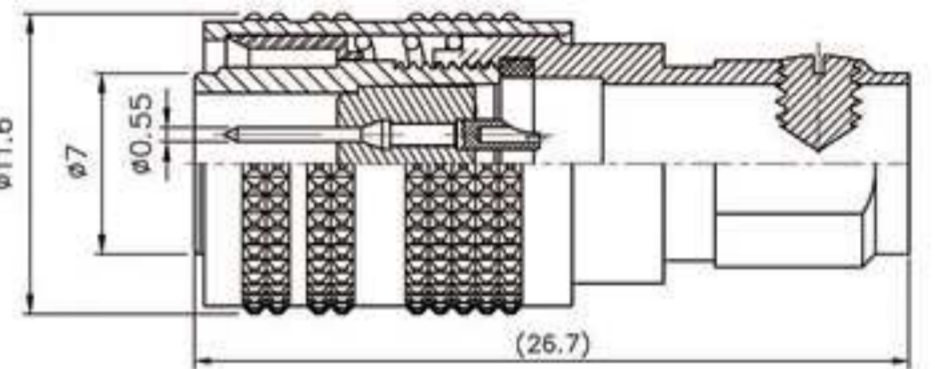

PLT-8-PM-R

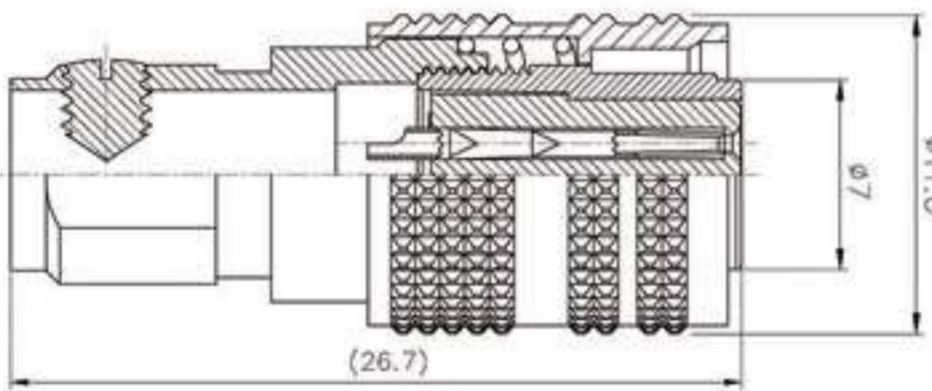

PLT-8-PF-R

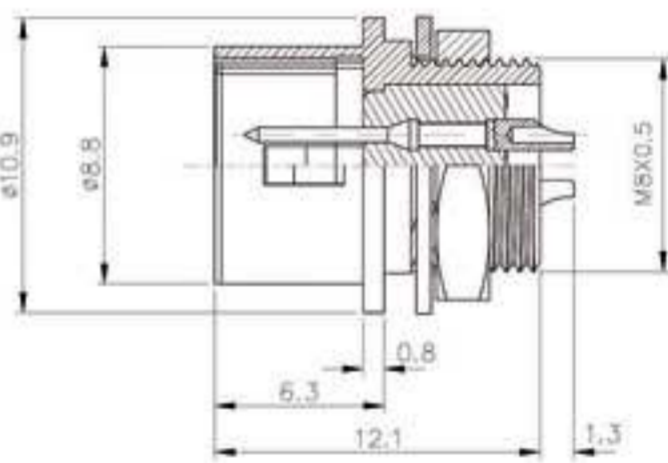
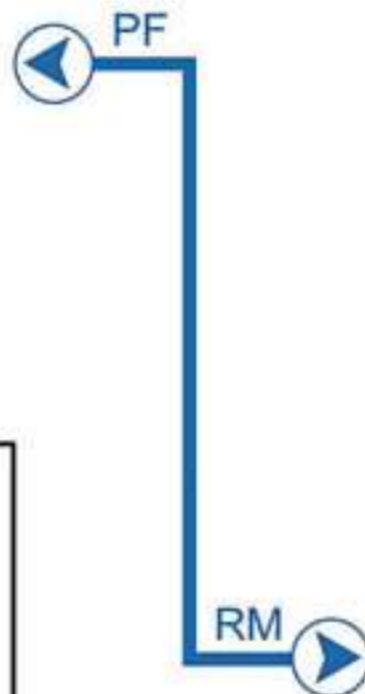

PLT-8-RM-R

ACCESSORIES:

Cable Clamp W-017BH

Rubber Pipe

◆ No. of contacts	4	5	6				
Contacts Configuration							
Rated current / voltage	1A 300V	1A 300V	1A 300V				
Operating voltage limit (AC.V.rms)	125	125	125				
Withstanding voltage (AC.V.rms) 1 minute	300	300	300				
Insulation resistance (MΩ MIN.) at DC 500V	1000	1000	1000				
Contact resistance (mΩ MAX.) at DC 1A	10	10	10				

● 以上機種可設計防水型 Above models could be altered to waterproof types





Output Type



PLT SERIES 2

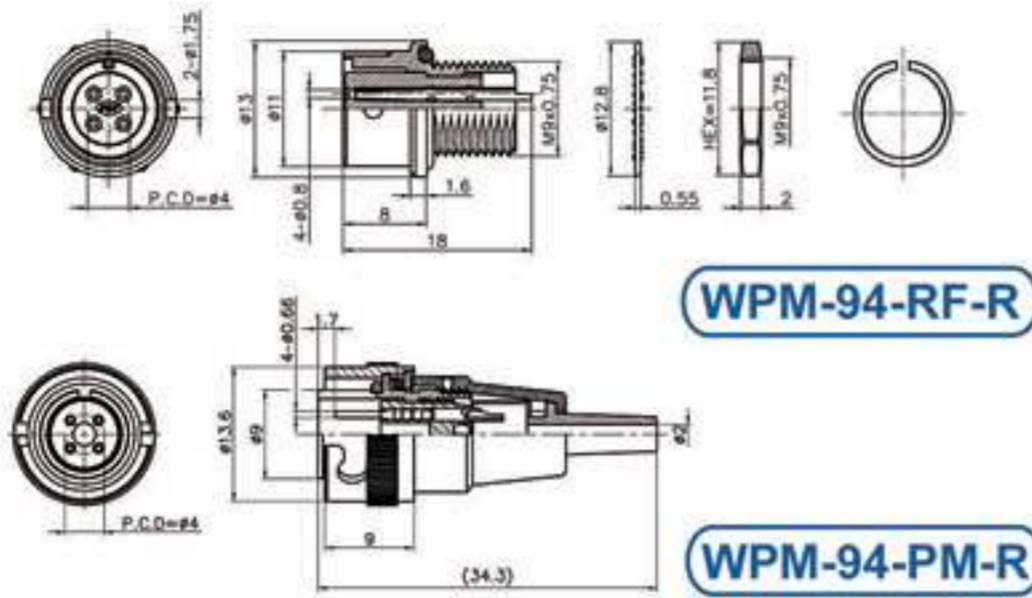

◆ No. of contacts	4				
Contacts Configuration					
Rated Current / Voltage	1A 300V				
Operating Voltage Limit (AC.V.rms)	AC 100V DC 140V				
Withstanding Voltage(AC. V. rms) 1 minute	300				
Insulation Resistance (MΩ min.) at DC 1A	200				
Contact Resistance (MΩ MAX.) at DC 1A	10				

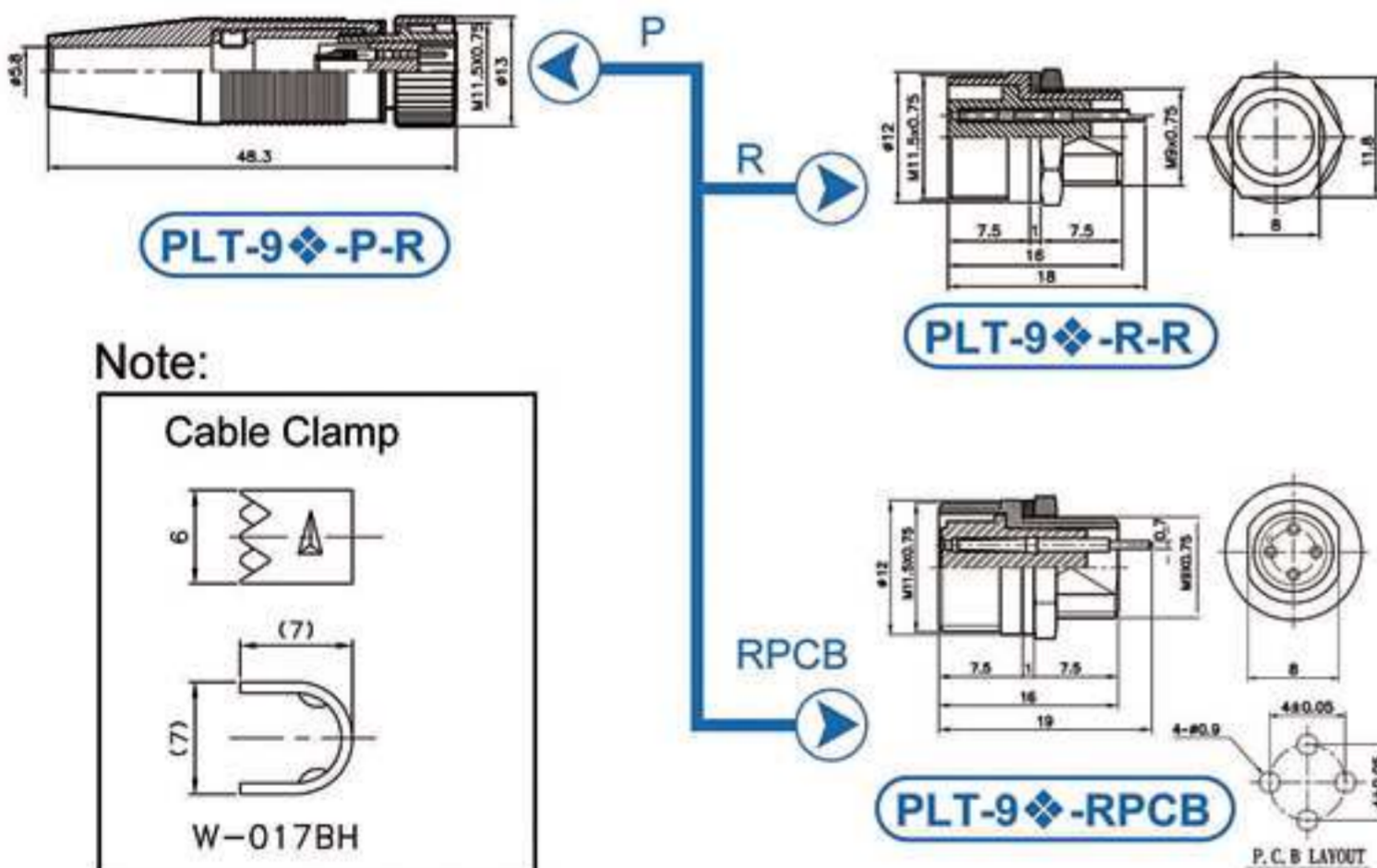

Note:

Cable Clamp

W-017BH

◆ No. of contacts	4	6	7		
Contacts Configuration					
Rated Current / Voltage	1A 300V	1A 300V	1A 300V		
Operating Voltage Limit (AC.V.rms)	300 AC300V	300 AC300V	300 AC300V		
Withstanding Voltage(AC. V. rms) 1 minute	200	200	200		
Insulation Resistance (MΩ MAX.) at DC 500V	10	10	10		
Contact Resistance (MΩ MAX.) at DC 1A	0.7	0.7	0.7		



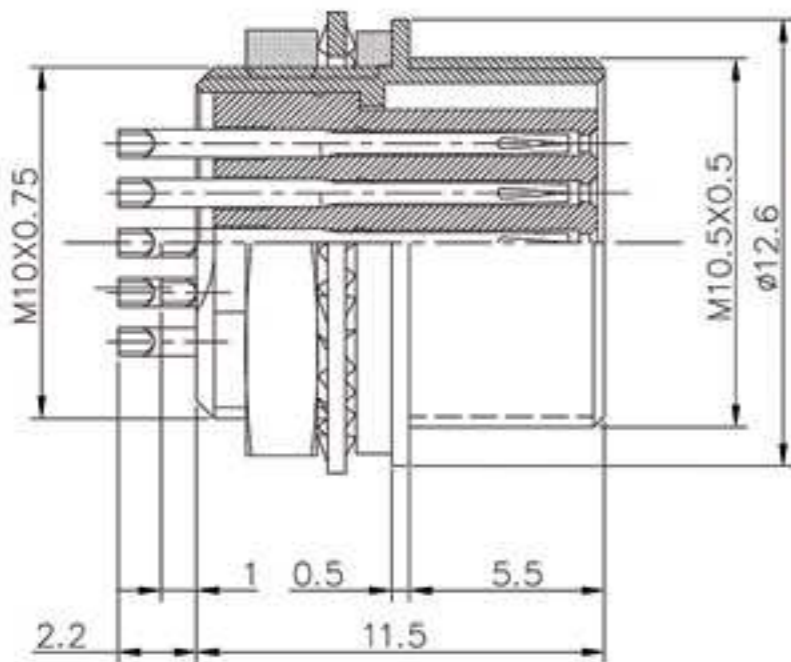

PLT-10-RF-R



PLT-10 Series

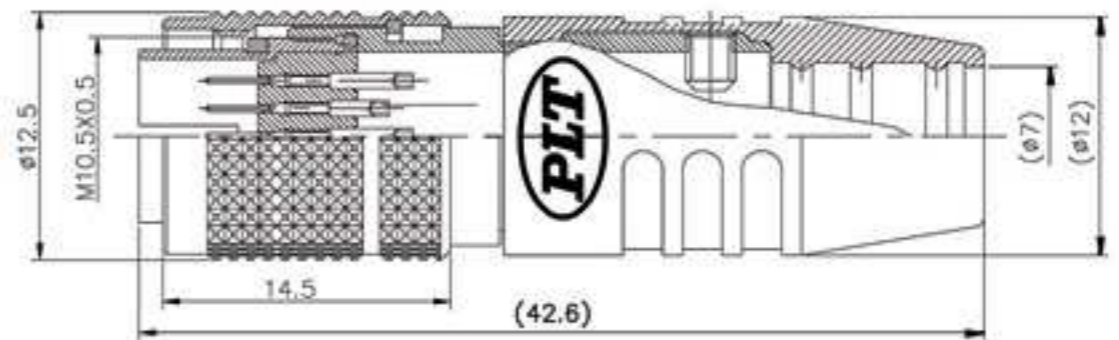

PLT-10-PM-R

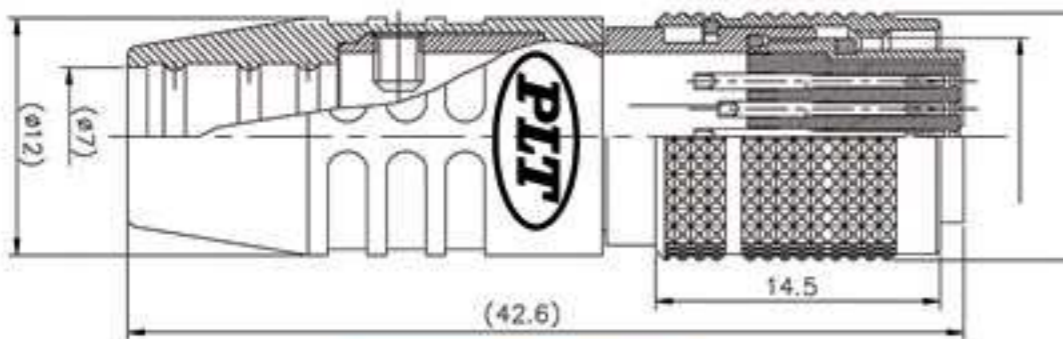

PLT-10-PF-R

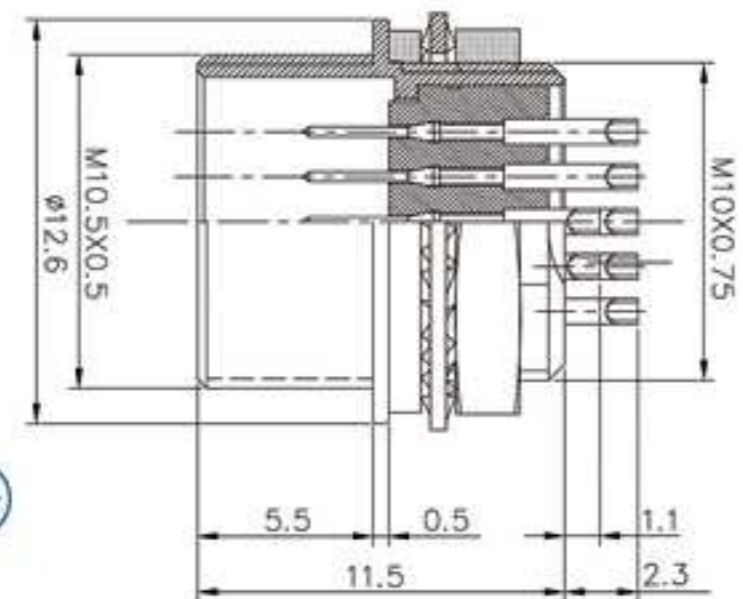
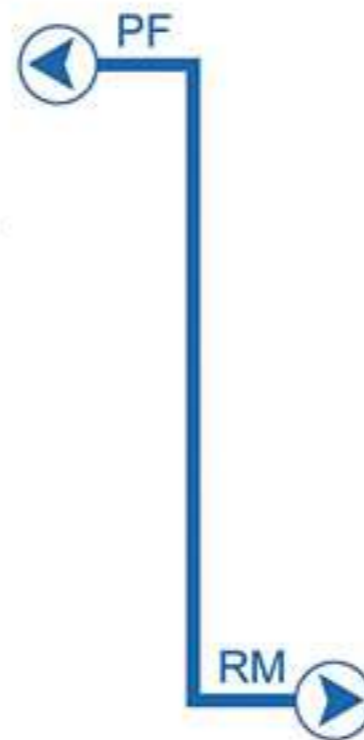

PLT-10-RM-R

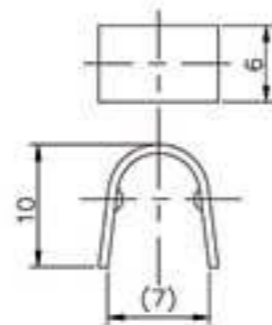

◆ No. of contacts	16				
Contacts Configuration					
Rated current / voltage	1A 30V				
Operating voltage limit (AC.V.rms)	42V				
Withstanding voltage (AC.V.rms) 1 minute	100				
Insulation resistance (MΩ MIN.) at DC 500V	1000				
Contact resistance (mΩ MAX.) at DC 1A	30				

Input Type / Output Type

PLT SERIES 2

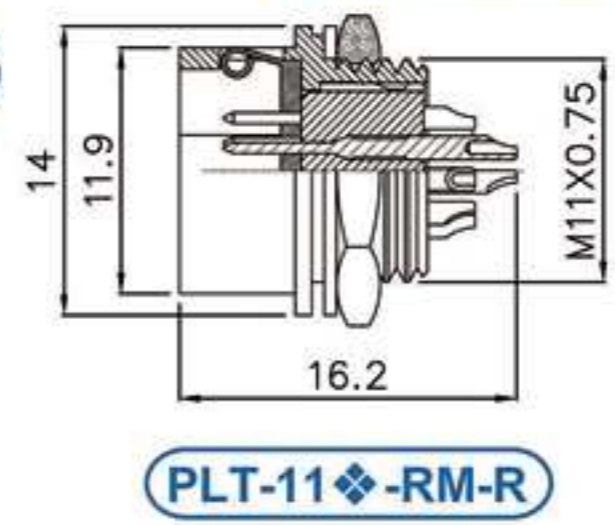
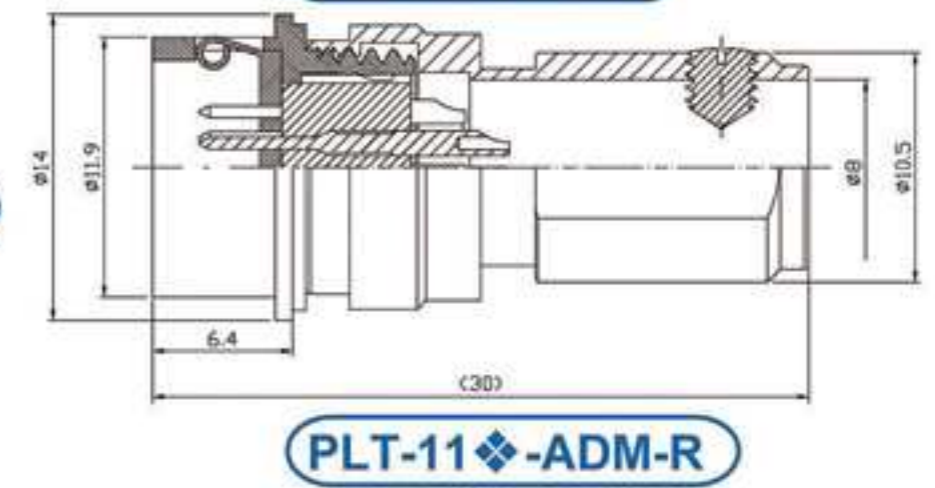
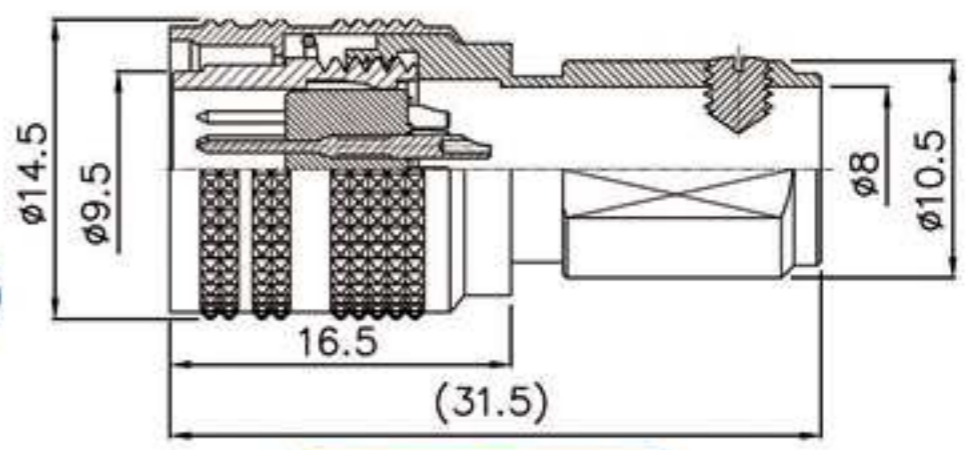
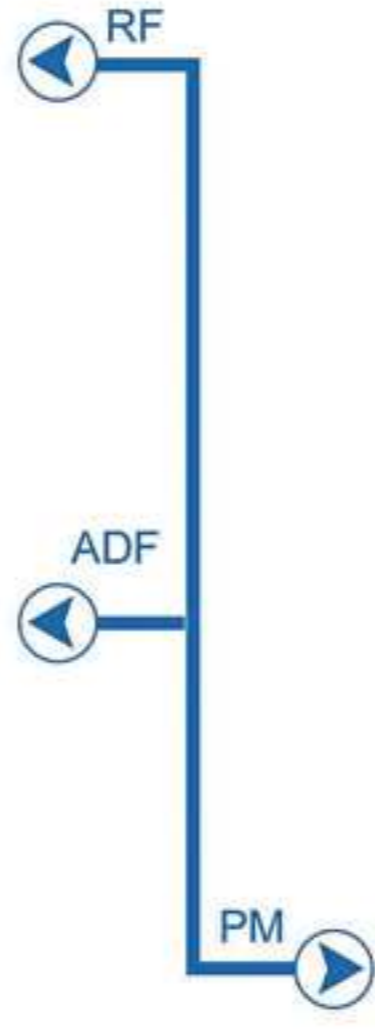
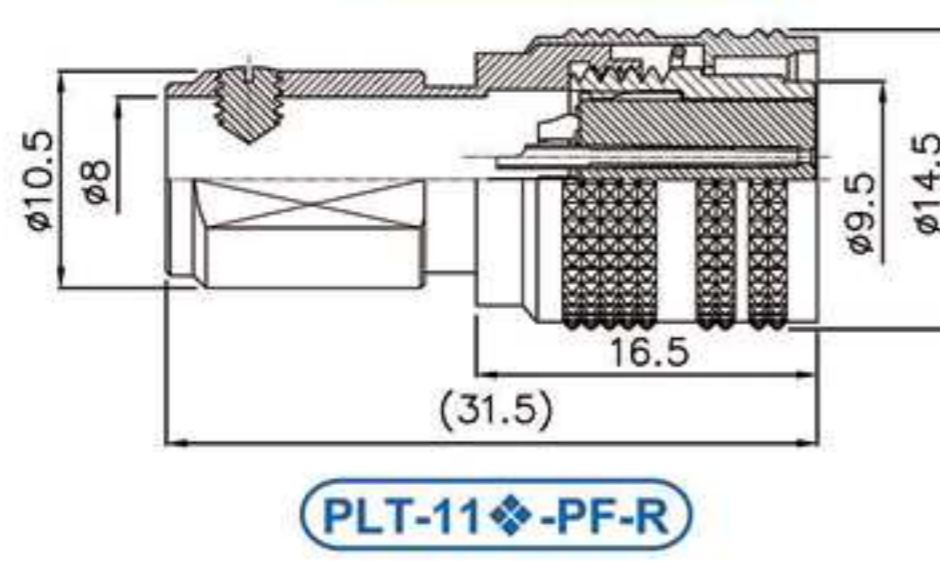
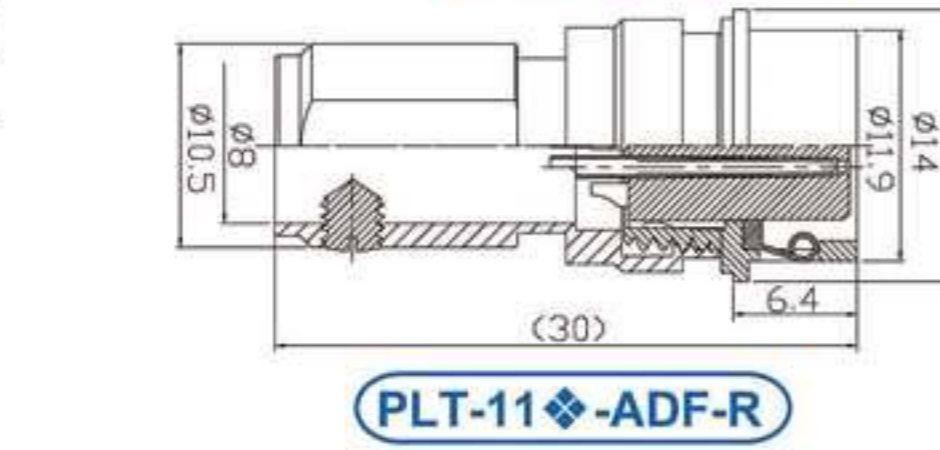
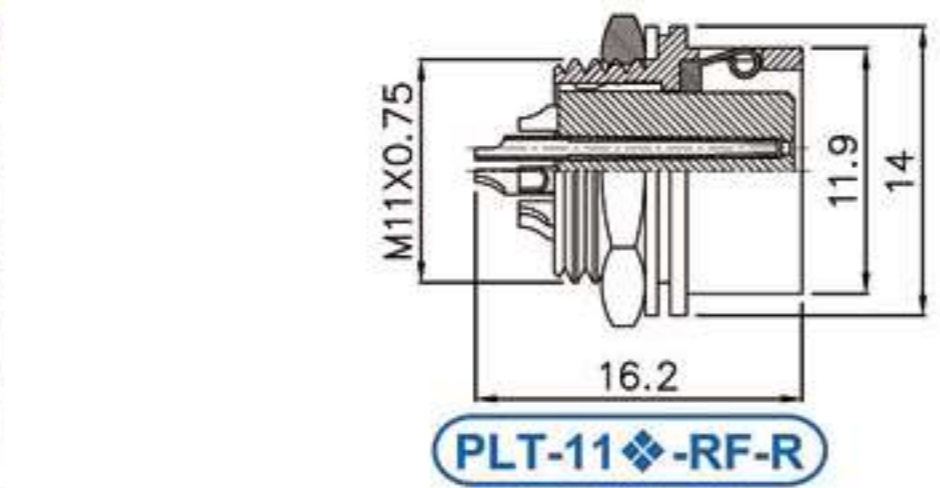

ACCESSORIES:

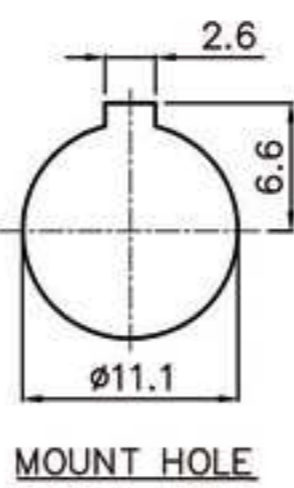
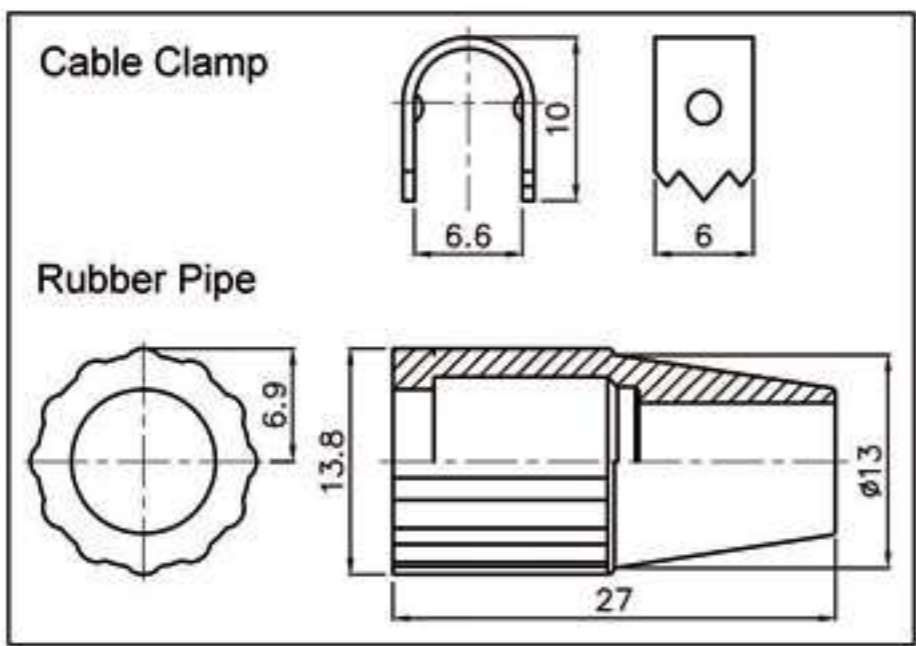

◆ No. of contacts	10	12	16		
Contacts Configuration					
Rated current / voltage	2A 125V	2A 125V	1A 30V		
Operating voltage limit (AC.V.rms)	125	125	42V		
Withstanding voltage (AC.V.rms) 1 minute	125	125	100		
Insulation resistance (MΩ MIN.) at DC 500V	200	200	1000		
Contact resistance (mΩ MAX.) at DC 1A	30	30	30		

14

TÜV

Output Type

2
PLT SERIES

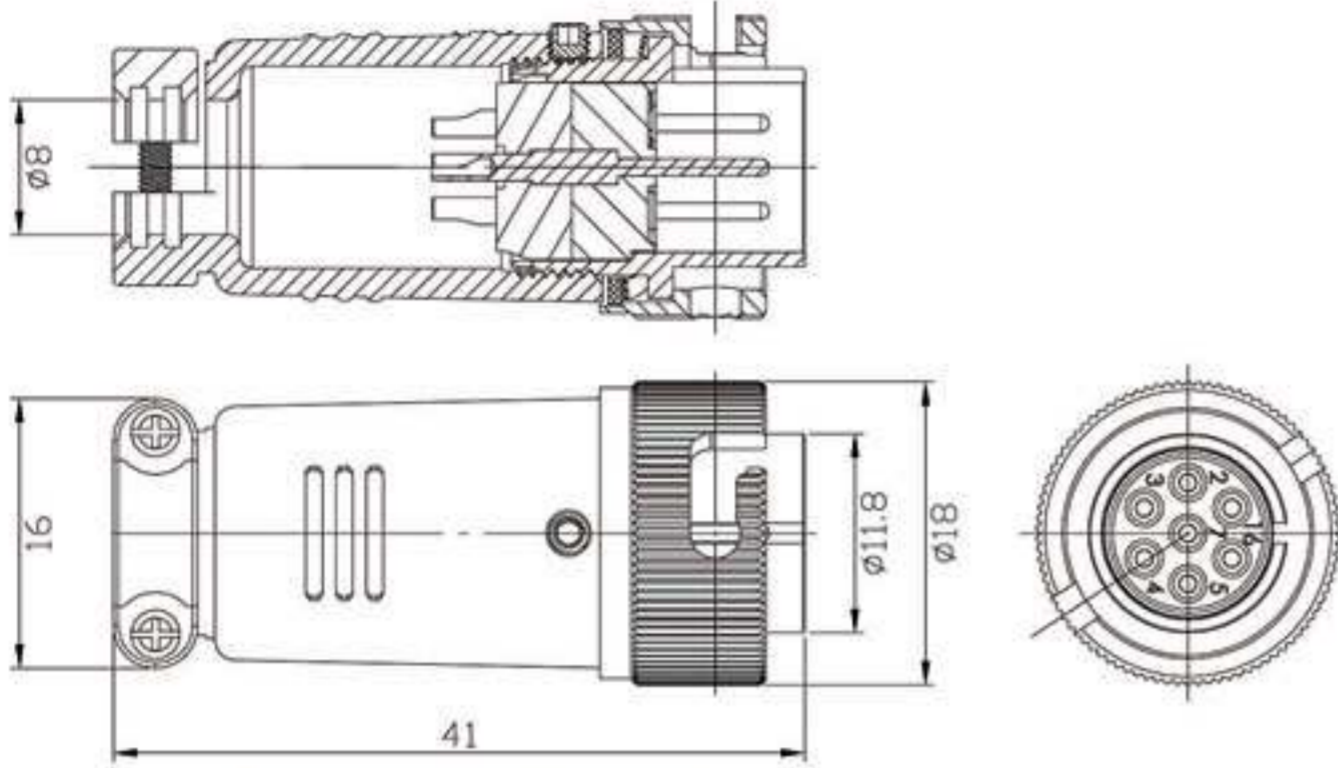

PLT-14 -PM-R



PLT- 14 Series

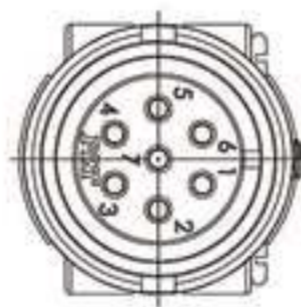

PLT-14 -ADF-R

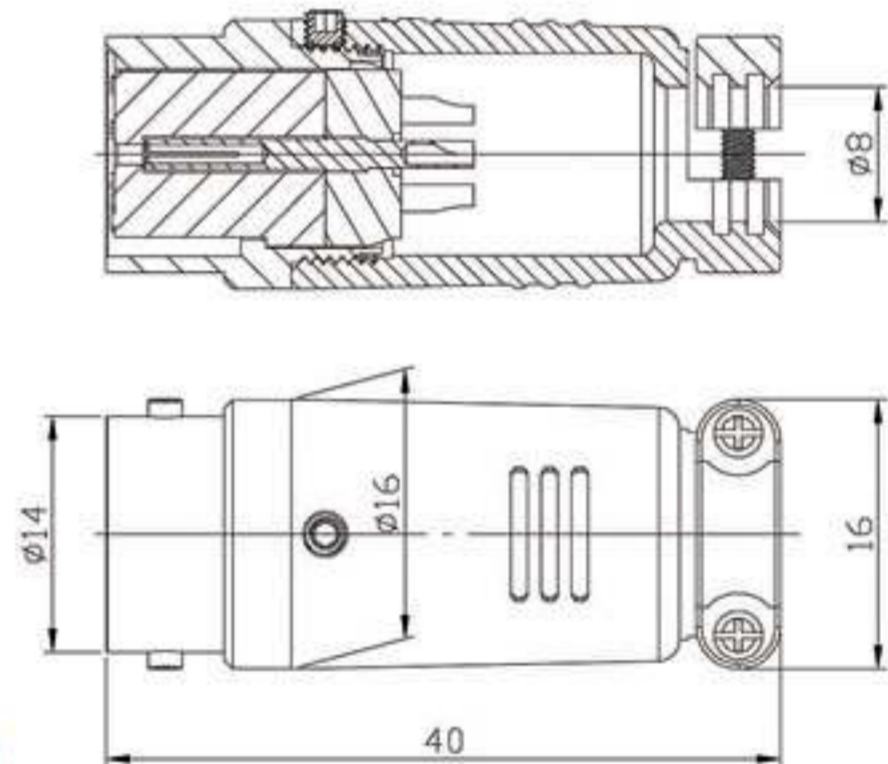

No. of contacts	3	4	7			
Contacts Configuration						
Rated current / voltage	5A 125V	5A 125V	5A 125V			
Operating voltage limit (AC.V.rms)	300	300	300			
Withstanding voltage (AC.V.rms) 1 minute	1000	1000	1000			
Insulation resistance (MΩ MIN.) at DC 500V	1000	1000	1000			
Contact resistance (mΩ MAX.) at DC 1A	4	4	4			

● 以上機種可設計防水型 Above models could be altered to waterproof types



Input Type

PLT SERIES 2

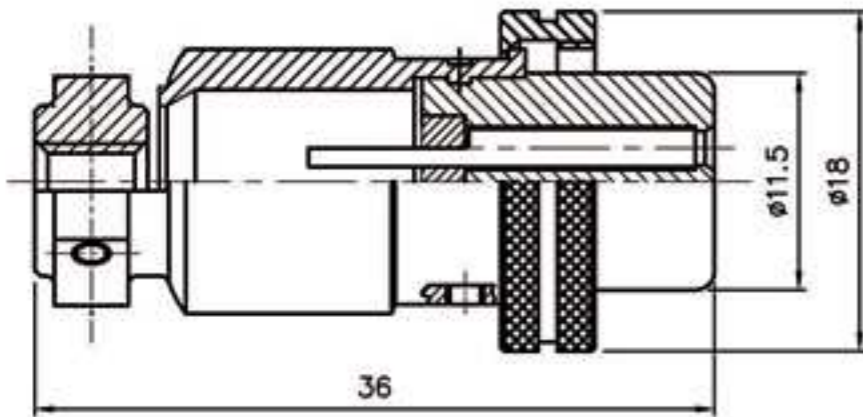

PLT-15-P-R



PLT-15 Series

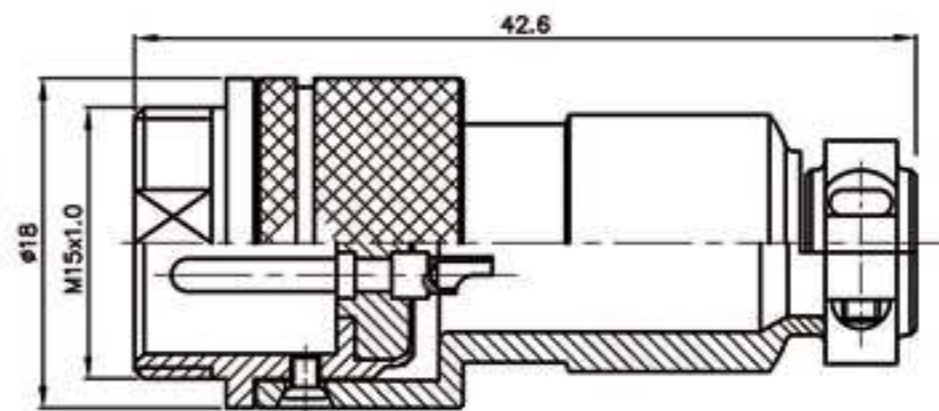
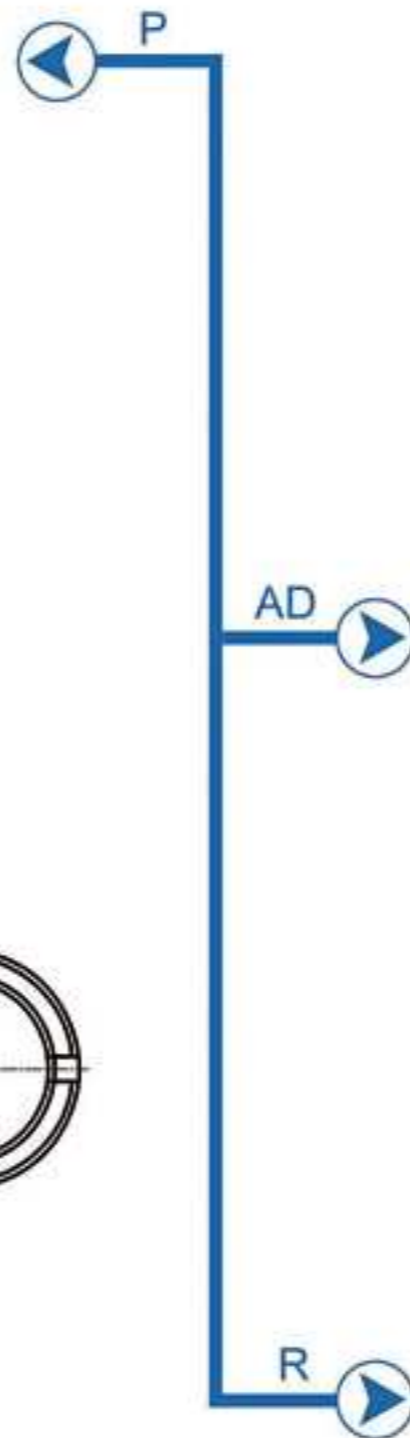

PLT-15-AD-R

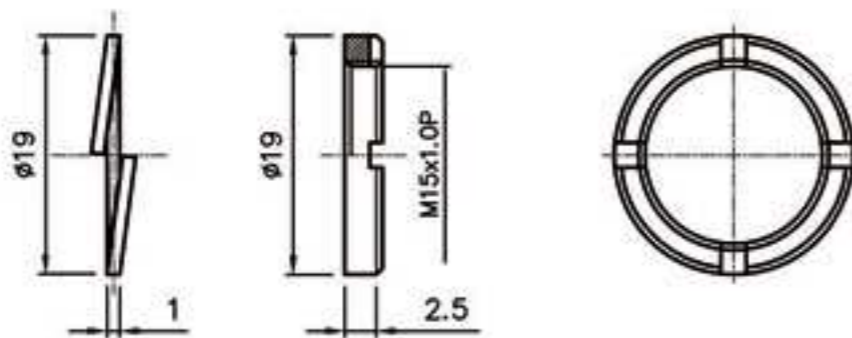

ACCESSORIES

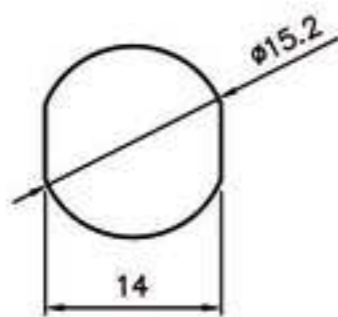

MOUNTING HOLES

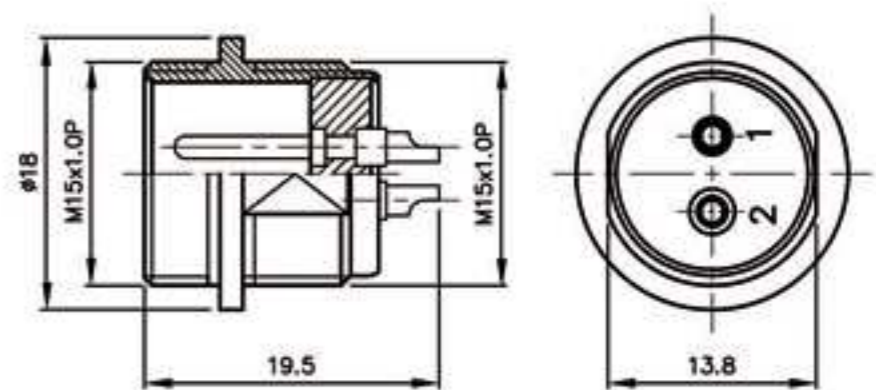

PLT-15-R-R

◆ No. of contacts	2	3	4			
Contacts Configuration						
	TÜV	TÜV	TÜV			
Rated current / voltage	5A 125V	5A 125V	5A 125V			
Operating voltage limit (AC.V.rms)	200	200	200			
Withstanding voltage (AC.V.rms) 1 minute	1000	1000	1000			
Insulation resistance (MΩ MIN.) at DC 500V	100	100	100			
Contact resistance (mΩ MAX.) at DC 1A	10	10	10			
Solder inter diameter	1.8 / 2.3	1.8 / 2.3	1.5			

15.5

cUL[®] TUV

2

PLT SERIES

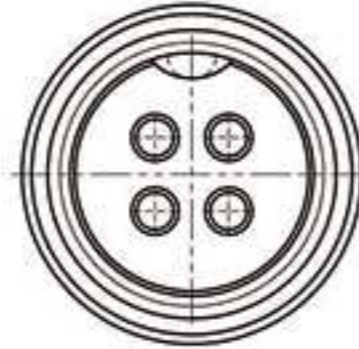
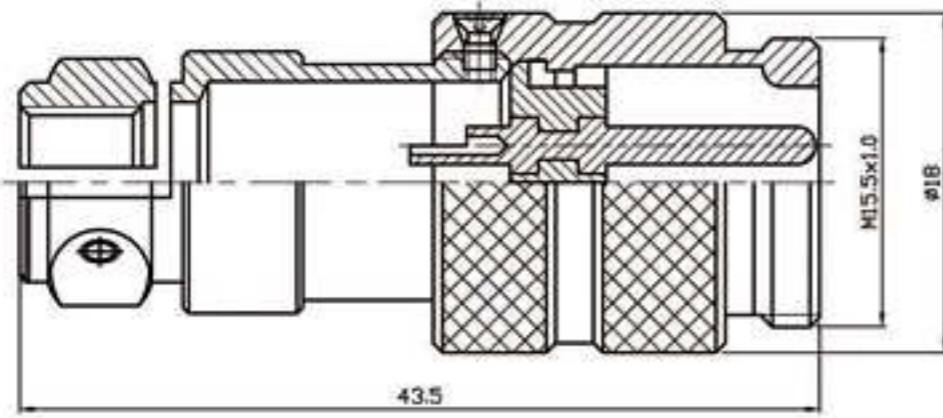

PLT- 15.5 Series

PLT-15.5-4AD-R

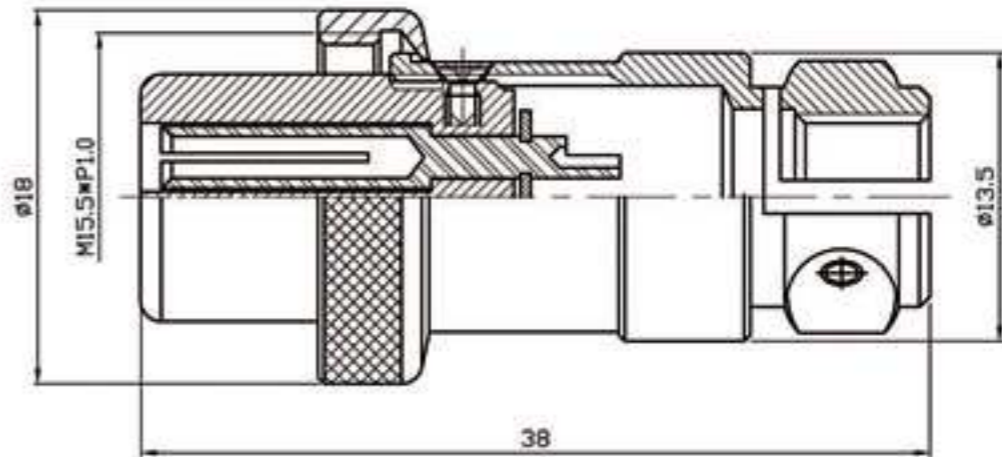
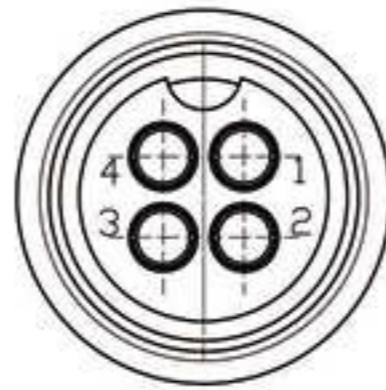

PLT-15.5-4P-R

◆ No. of contacts	4				
Contacts Configuration					
Rated current / voltage	5A 150V				
Operating voltage limit (AC.V.rms)	200				
Withstanding voltage (AC.V.rms) 1 minute	1000				
Insulation resistance (MΩ MIN.) at DC 500V	1000				
Contact resistance (mΩ MAX.) at DC 1A	3				
Solder inter diameter	1				

● 以上機種可設計防水型 Above models could be altered to waterproof types

Input Type

PLT SERIES 2

PLT-16-P-R

PLT-16-LP-R

PLT-16-PA-R Material: Zinc Alloy 材質: 鋅合金

PLT-16-R-R

PLT-16-RL-R Material: Zinc Alloy 材質: 鋅合金

PLT-16-RCaC-R

PLT-16-RCa-R Material: Brass 材質: 銅

U-C5 Material: Brass 材質: 銅

PLT-16-ADA-R

PLT-16-AD-R PD:98441

PIN	2	3	4	5	6	7	8
L	20.5	20.5	20.5	20.5	19	19	19

FORM 1 FOR PLT-16*-RL

LENGTH	L1	L2	L3	L4	L5	L6
SIZE	20.5	23.5	29	30.5	21.5	21.5

*FORM 2 (ACCESSORIES)

A1, A2, A3, A4

*A: PCB TYPE
*B: SOLDERING TYPE

(Patent of invention, all rights reserved 專利產品、仿冒必究)

◆ No. of contacts	2	3	4	5	6	7	8
Contacts Configuration							
Rated current / voltage	5A 125V	5A 125V	5A 125V	5A 125V	5A 125V	5A 125V	5A 125V
Operating voltage limit (AC.V.rms)	200	200	200	200	200	200	200
Withstanding voltage (AC.V.rms) 1 minute	1000	1000	1000	1000	1000	1000	1000
Insulation resistance (MΩ MIN.) at DC 500V	1000	1000	1000	1000	1000	1000	1000
Contact resistance (mΩ MAX.) at DC 1A	3	3	3	3	3	3	3
Solder inter diameter	1.4	1.4	1.4	1.2	0.8	0.8	0.8



Output Type

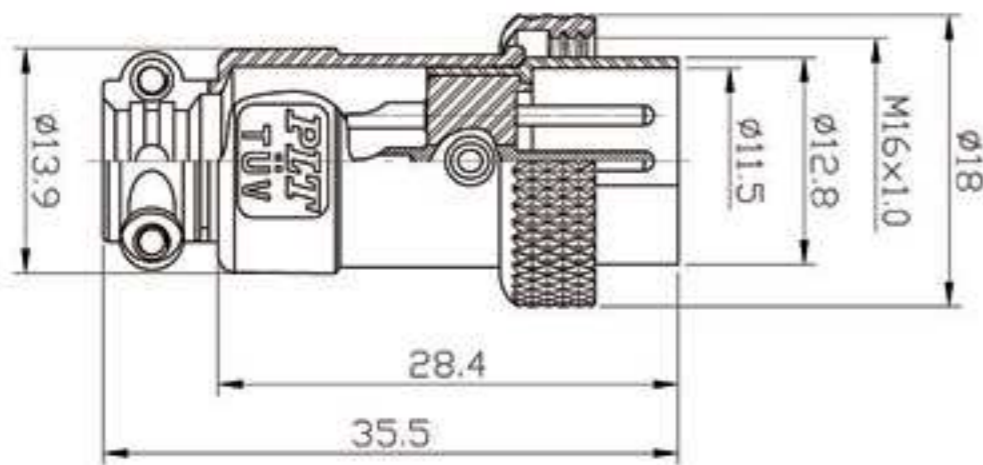

PLT-16-PM-R

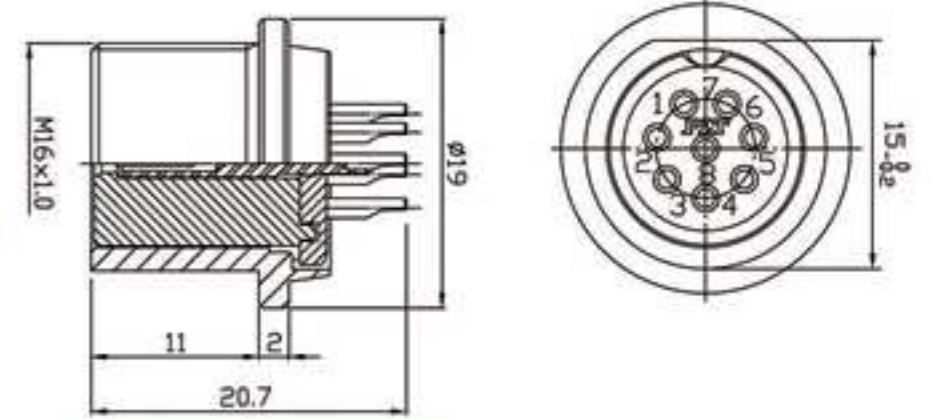

PLT-16-RLF-R

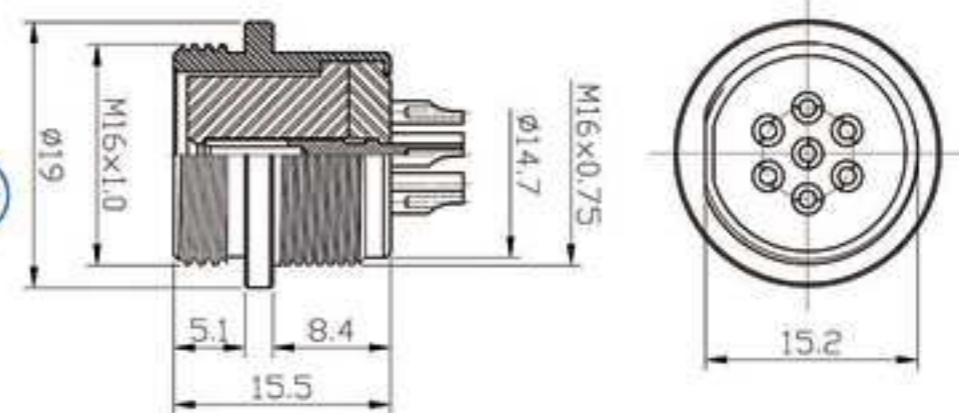

PLT-16-RF-R

◆ No. of contacts	2	3	4	5	6	7	8
Contacts Configuration							
Rated current / voltage	5A 125V	5A 125V	5A 125V	5A 125V	5A 125V	5A 125V	5A 125V
Operating voltage limit (AC.V.rms)	200	200	200	200	200	200	200
Withstanding voltage (AC.V.rms) 1 minute	1000	1000	1000	1000	1000	1000	1000
Insulation resistance (MΩ MIN.) at DC 500V	1000	1000	1000	1000	1000	1000	1000
Contact resistance (mΩ MAX.) at DC 1A	3	3	3	3	3	3	3
Solder inter diameter	1.4	1.4	1.4	1.2	0.8	0.8	0.8

● 以上機種可設計防水型 Above models could be altered to waterproof types



Output Type

PLT SERIES 2

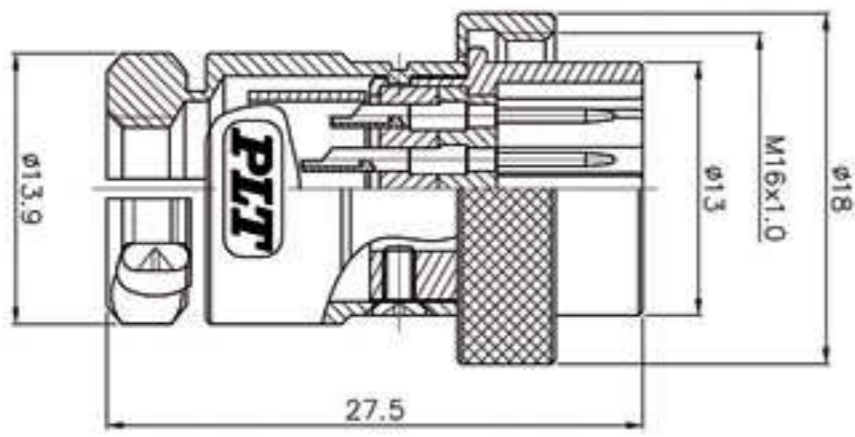

PLT-16A-PM-R



PLT-16A Series

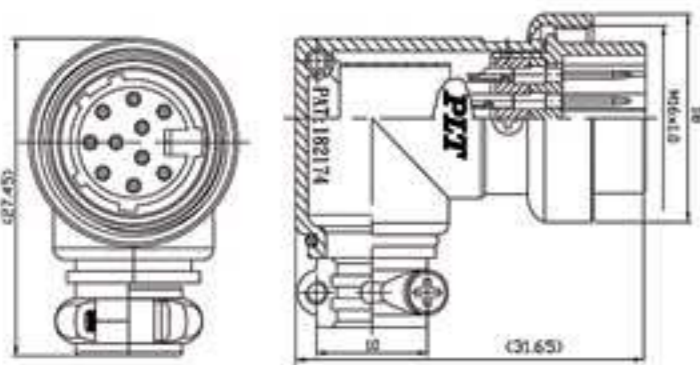

PLT-16A-LPM-R

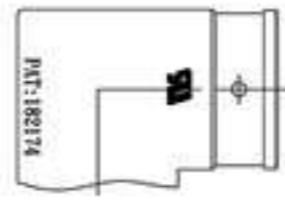

LPM-R

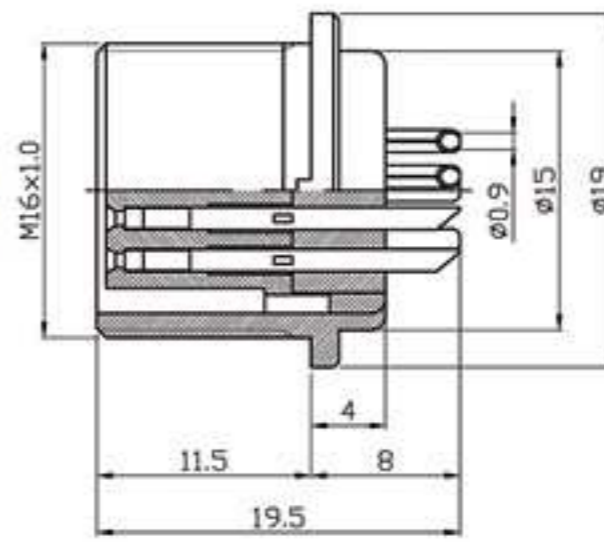

PLT-16A-RF-R

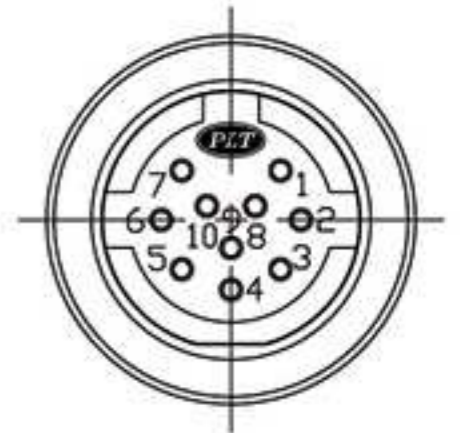

◆ No. of contacts	10							
Contacts Configuration								
Withstanding voltage (AC.V.rms) 1 minute	1000							
Insulation resistance (MΩ MIN.) at DC 500V	100							
Contact resistance (mΩ MAX.) at DC 1A	10							

17



Input Type

2

PLT SERIES

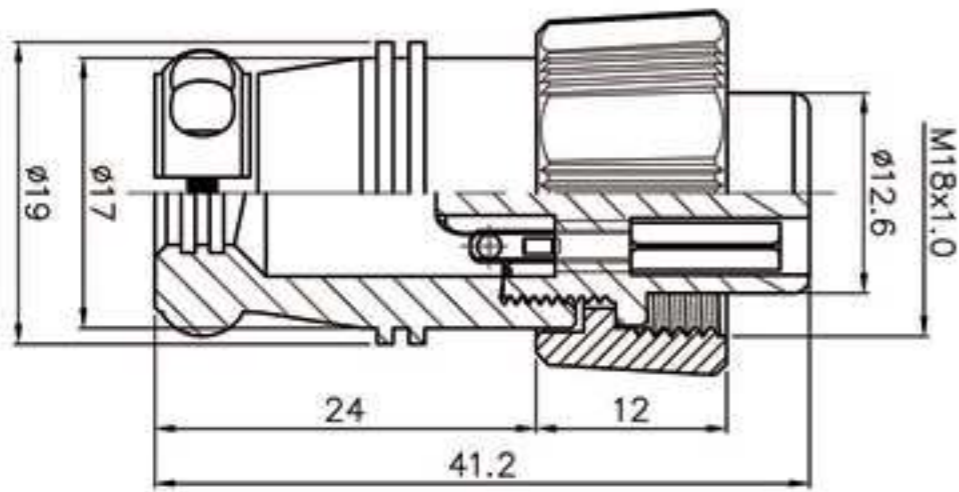

PLT-17-P-R



PLT-17 Series

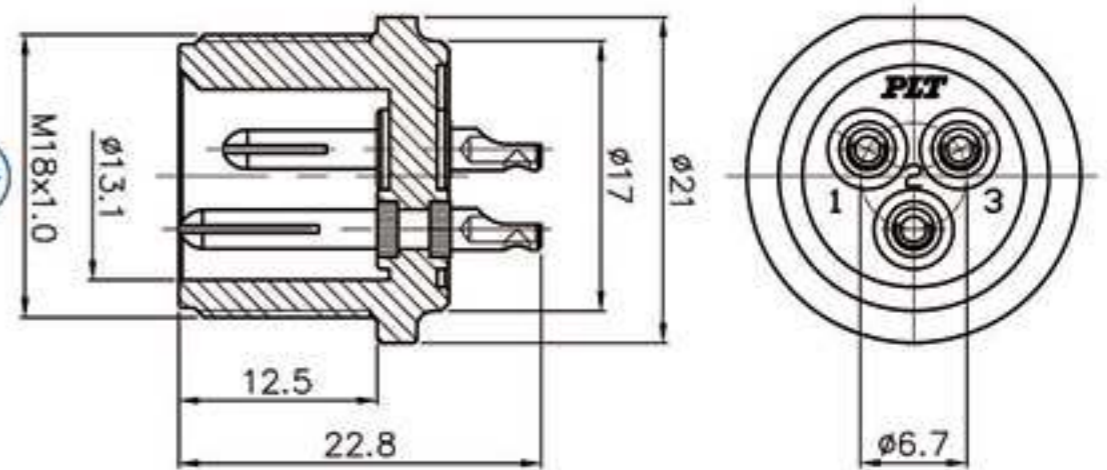

PLT-17-R-R

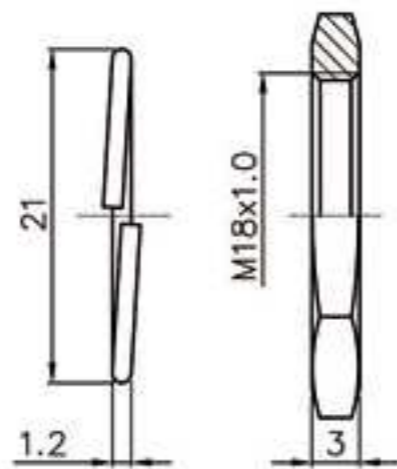

ACCESSORIES

(Engineering Plastic 工程塑膠)

◆ No. of contacts	2	3	4	5	6	7	8
Contacts Configuration							
Rated current / voltage	5A 125V	5A 125V	5A 125V	5A 125V	5A 125V	5A 125V	5A 125V
Operating voltage limit (AC.V.rms)	200	200	200	200	200	200	200
Withstanding voltage (AC.V.rms) 1 minute	1000	1000	1000	1000	1000	1000	1000
Insulation resistance (MΩ MIN.) at DC 500V	1000	1000	1000	1000	1000	1000	1000
Contact resistance (mΩ MAX.) at DC 1A	3	3	3	3	3	3	3
Solder inter diameter	1.4	1.4	1.4	1.2	0.8	0.8	0.8



● 以上機種可設計防水型 Above models could be altered to waterproof types

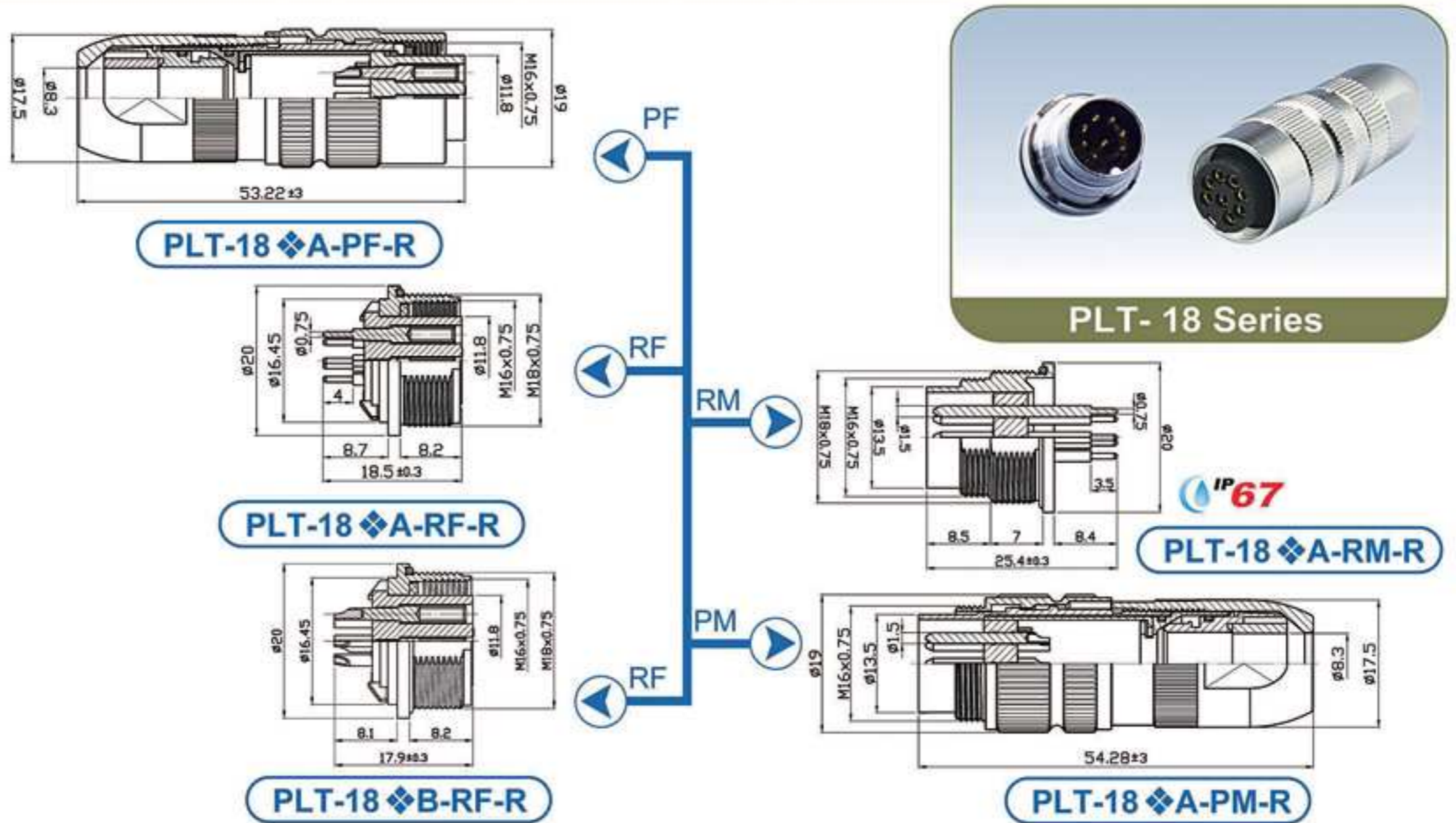
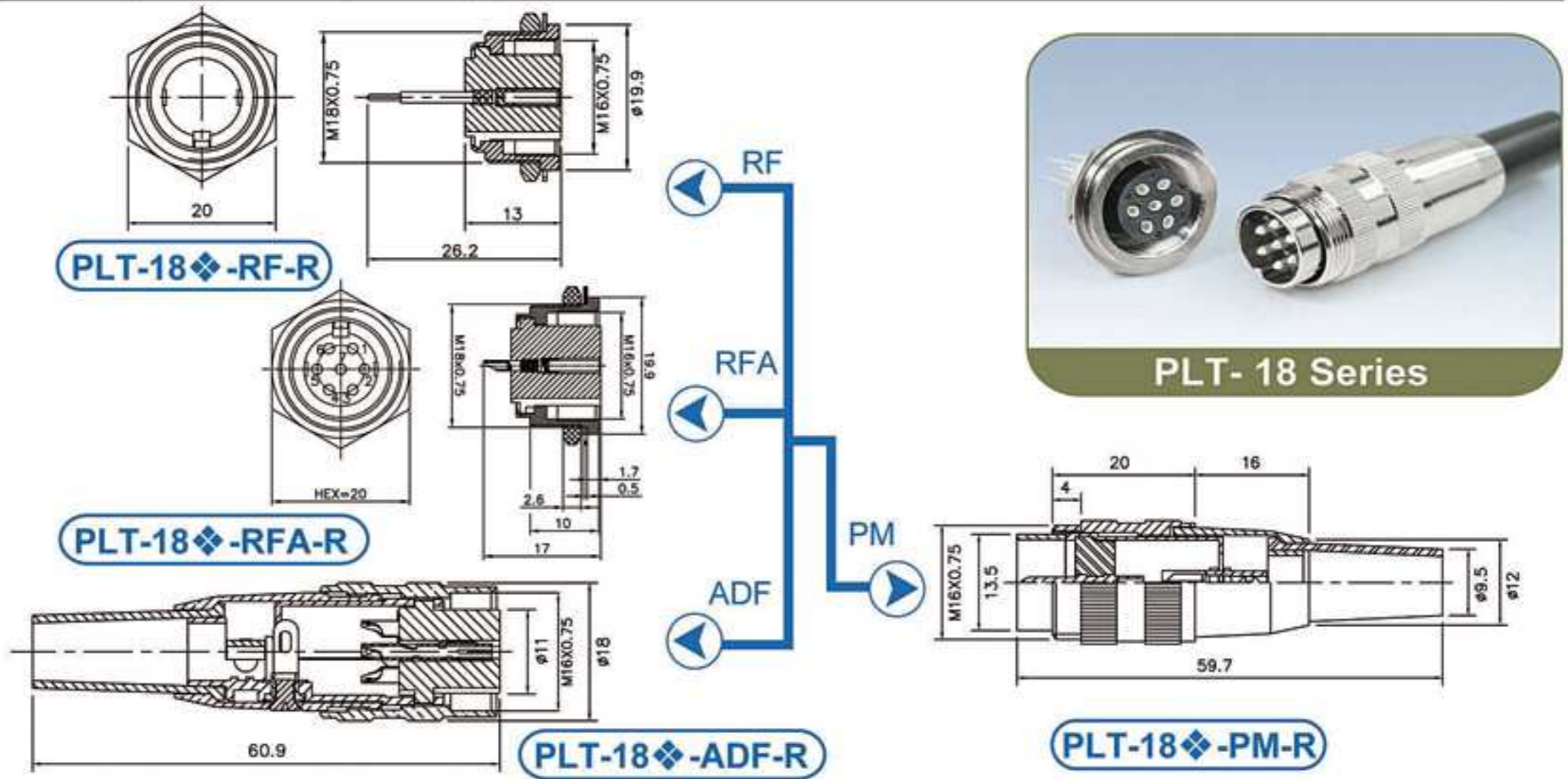

Input Type / Output Type

PLT SERIES 2



◆ No. of contacts	5	7	8			
Contacts Configuration	 TÜV	 TÜV	 TÜV			
Rated current / voltage	5A 125V	5A 125V	5A 125V			
Operating voltage limit (AC.V.rms)	200	200	200			
Withstanding voltage (AC.V.rms) 1 minute	1000	1000	1000			
Insulation resistance (MΩ MIN.) at DC 500V	1000	1000	1000			
Contact resistance (mΩ MAX.) at DC 1A	3	3	3			
Solder inter diameter	1.55	1.55	1.55			

19

TÜV

Input Type

2
PLT SERIES

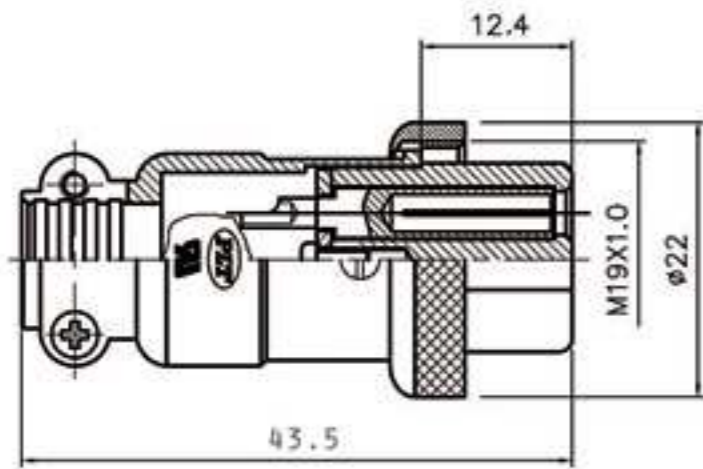

PLT-19-P-R

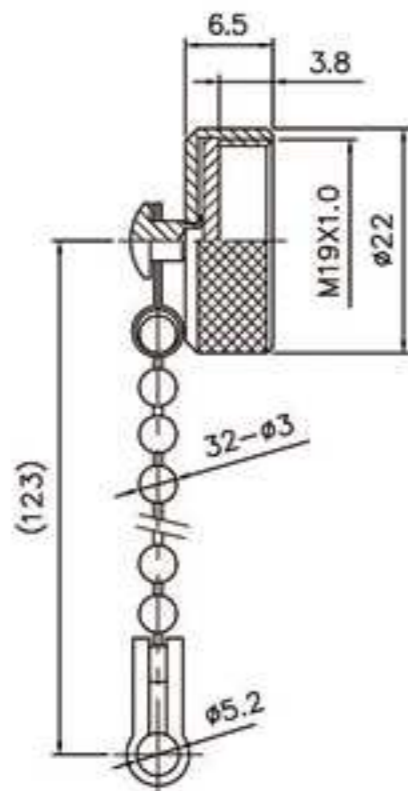

Material: Copper Alloy
材質: 銅合金



PLT-19-RCa-R

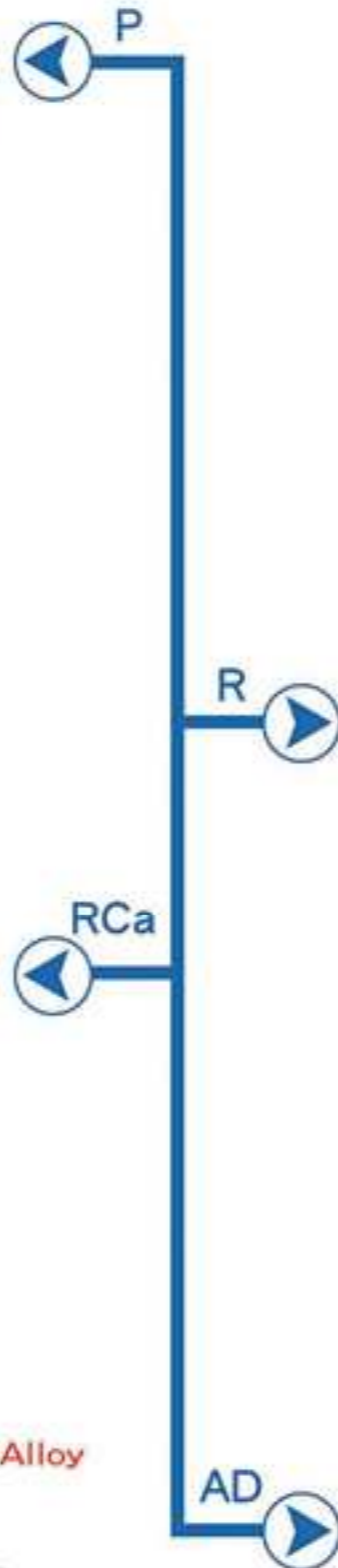

PLT-19 Series

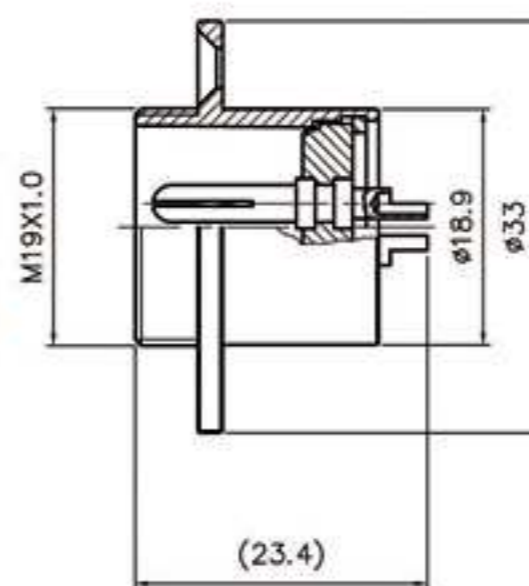

PLT-19-R-R

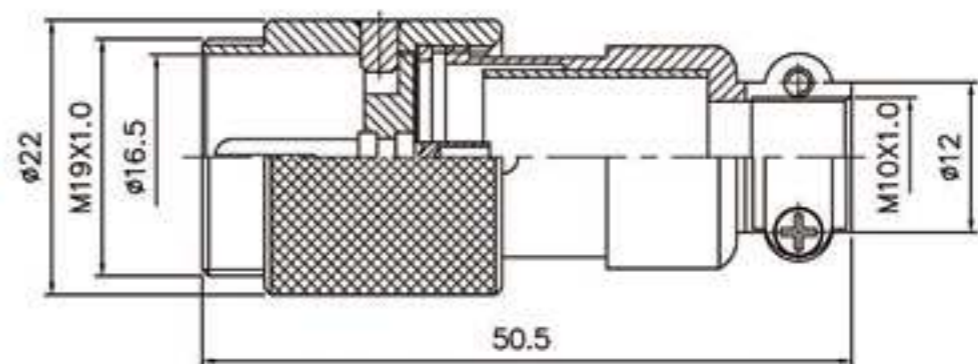
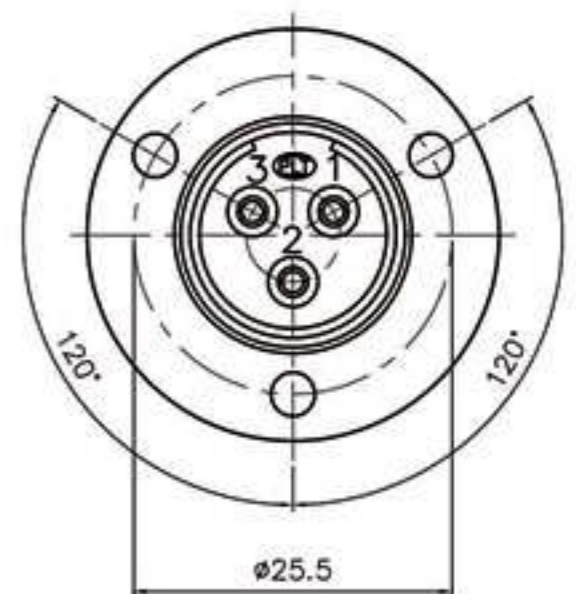

PLT-19-AD-R

◆ No. of contacts	2	3	4			
Contacts Configuration	 TÜV	 TÜV	 TÜV			
Rated current / voltage	7A 250V	7A 250V	7A 250V			
Operating voltage limit (AC.V.rms)	250	250	250			
Withstanding voltage (AC.V.rms) 1 minute	1000	1000	1000			
Insulation resistance (MΩ MIN.) at DC 500V	1000	1000	1000			
Contact resistance (mΩ MAX.) at DC 1A	3	3	3			
Solder inter diameter	1.7	1.7	1.7			

● 以上機種可設計防水型 Above models could be altered to waterproof types



Input Type

PLT SERIES 2



● 另有鎖側螺絲選項
Optional accessory: side screws

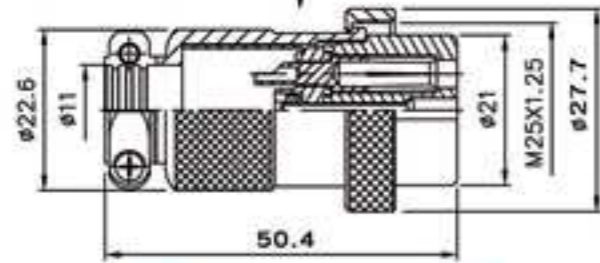

PLT-25-P-R

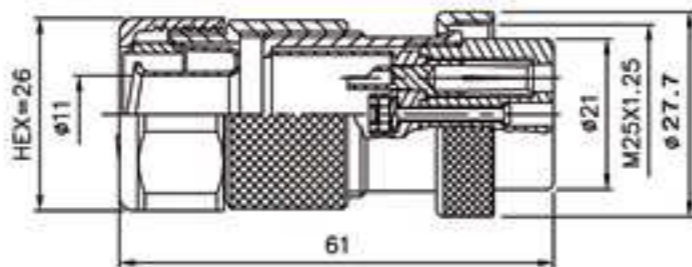

PLT-25-GP3-R 3=轉接3/8"軟管
Connected with 3/8"conduit

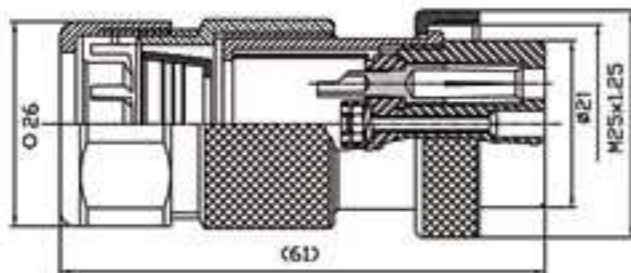

PLT-25-WGPF3-R 3=轉接3/8"尼龍管
Connected with 3/8"nylon tube

MATERIAL: ABS(BLACK)

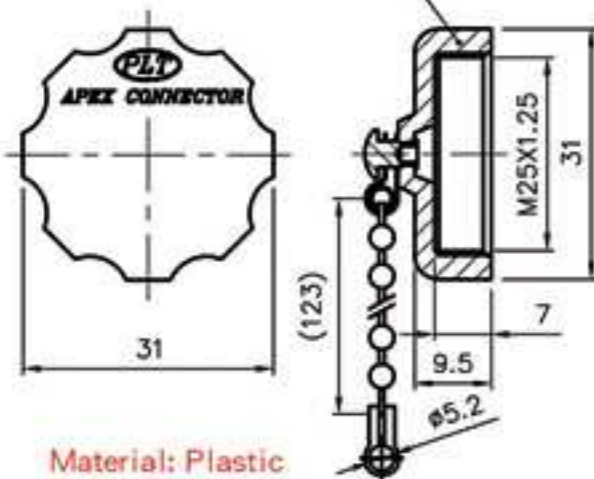

Material: Plastic
材質: 塑膠

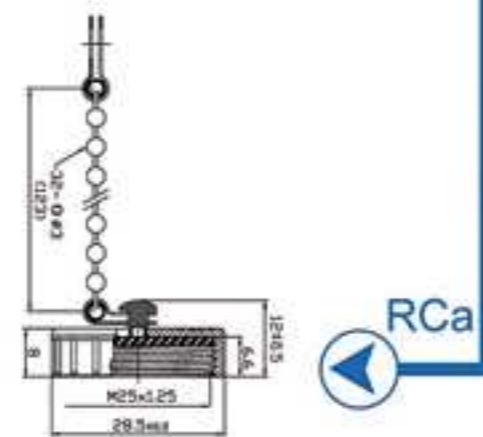

Material: Zinc Alloy
材質: 鋅合金



Material: Plastic
材質: 塑膠

PAT PLT-25A-RCa-R

PLT-25C-RCa-R

PAT A-590PX

● 本件加值不加價
Value-Added with the Same Price



PLT-25 Series

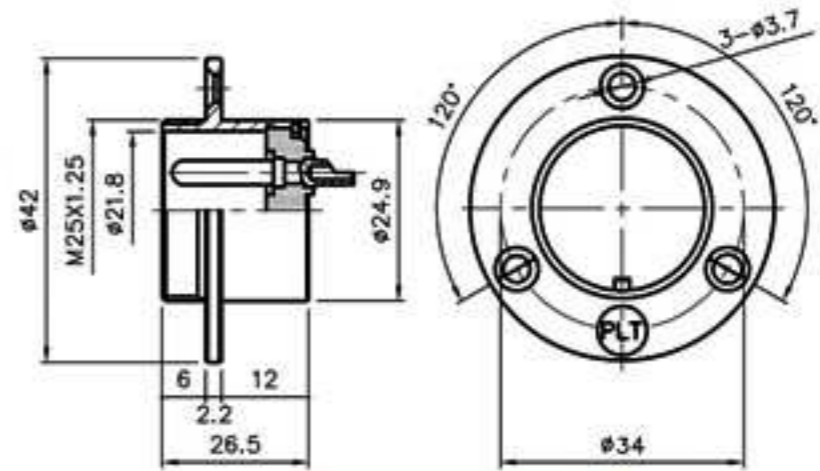
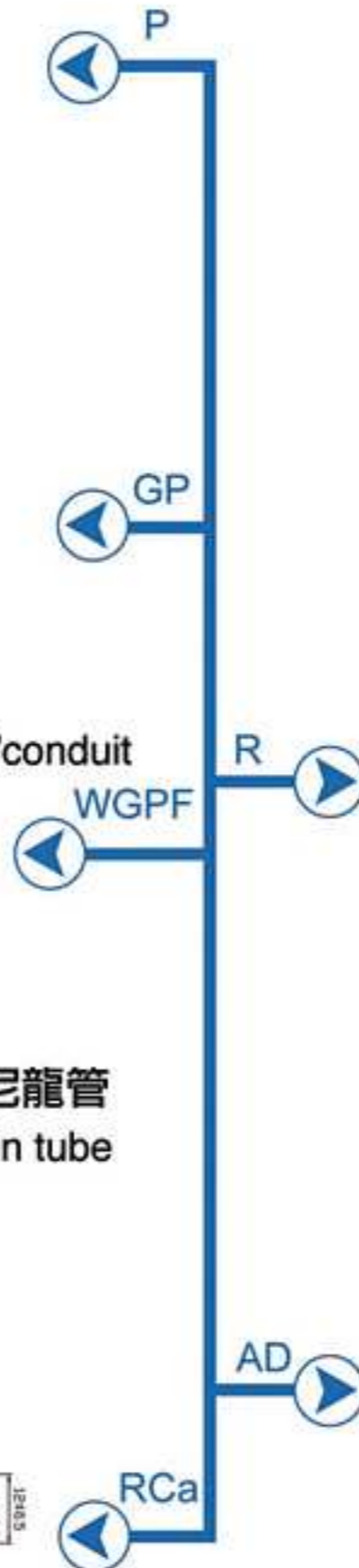

PLT-25-R-R

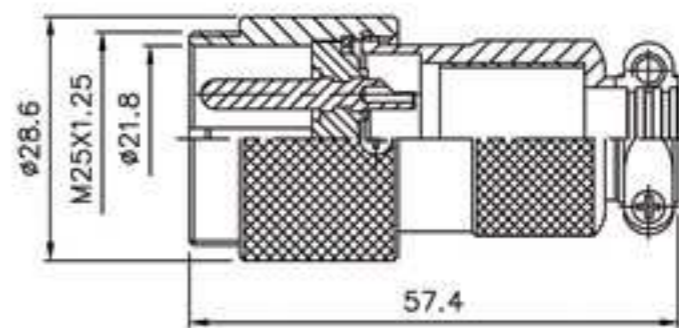

PLT-25-AD-R

◆ No. of contacts	2	3	4	5	6
Contacts Configuration	 TÜV	 TÜV	 TÜV	 TÜV	 TÜV
Rated current / voltage	10A 250V	10A 250V	10A 250V	10A 250V	10A 250V
Operating voltage limit (AC.V.rms)	400	400	400	400	300
Withstanding voltage (AC.V.rms) 1 minute	2000	2000	2000	1800	1800
Insulation resistance (MΩ MIN.) at DC 500V	2000	2000	2000	2000	2000
Contact resistance (mΩ MAX.) at DC 1A	3	3	3	3	3
Solder inter diameter	1.9	1.9	1.9	1.9	1.9

25

TÜV

Output Type

2
PLT SERIES



PLT-25 Series

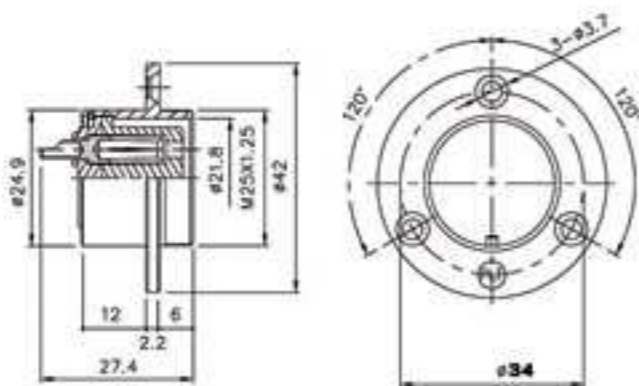

PLT-25-RF-R

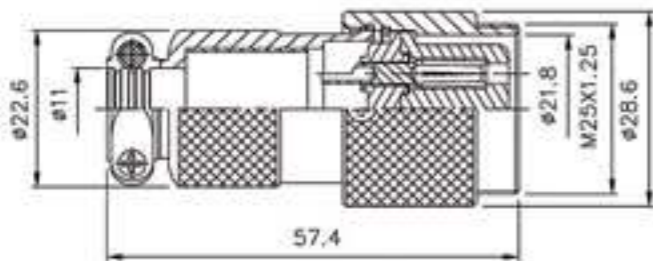

PLT-25-ADF-R

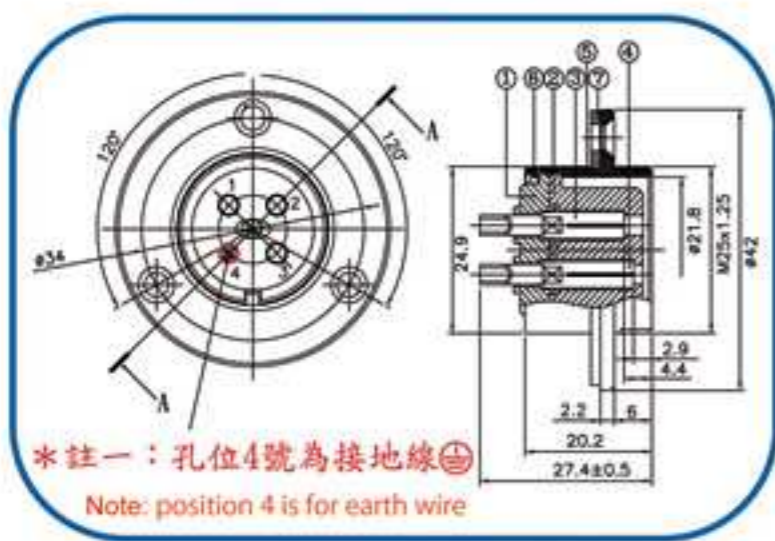

PLT-254E-RF-R

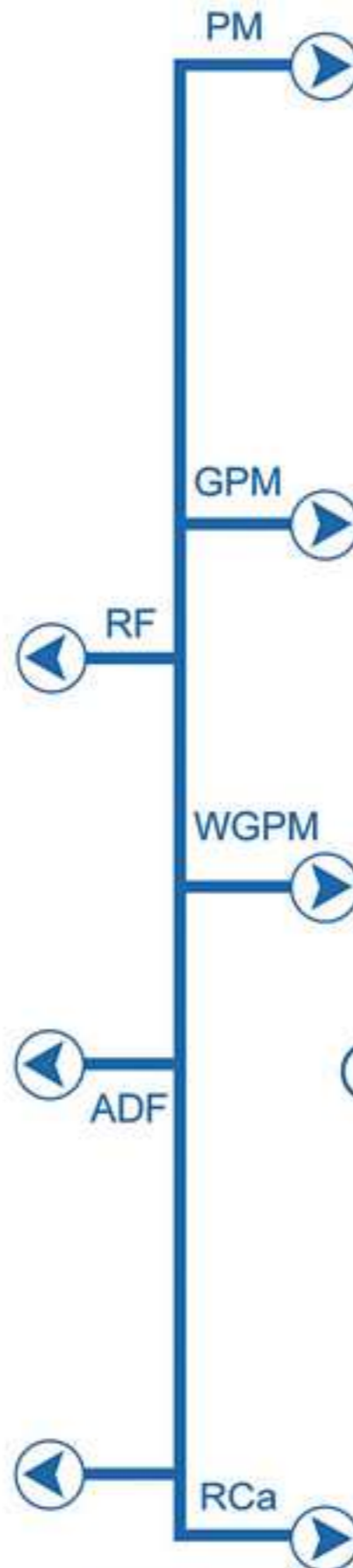

另有鎖側螺絲選項
Optional accessory: side screws

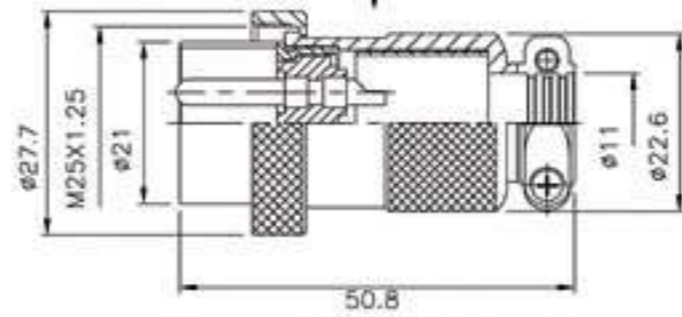

PLT-25-PM-R

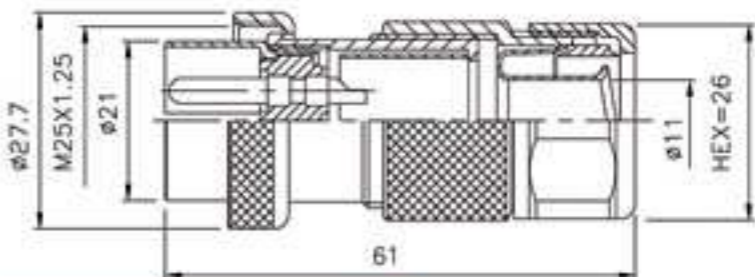

PLT-25-GPM3-R

3=轉接3/8"軟管
Connected with 3/8"conduit

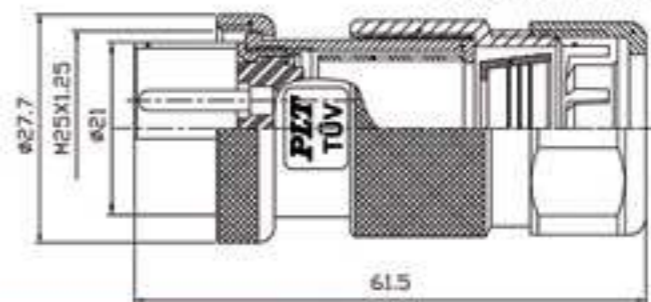

PLT-25-WGPM3-R

3=轉接3/8"尼龍管
Connected with 3/8"nylon tube

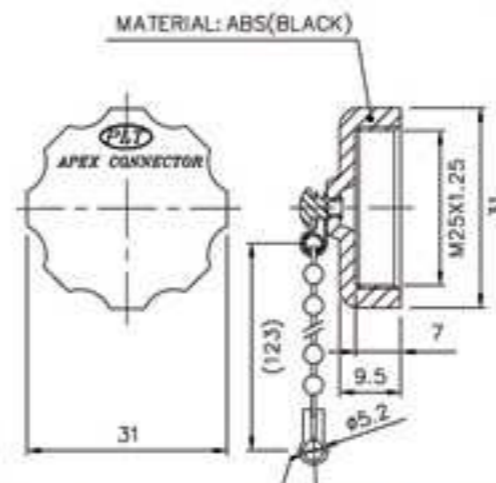

Material: Plastic
材質: 塑膠

Material: Plastic
材質: 塑膠

Material: Zinc Alloy
材質: 鋅合金

PAT A-590PX

本件加值不加價
Value-Added with the Same Price

PAT PLT-25A-RCa-R

PLT-25C-RCa-R

◆ No. of contacts	2	3	4	5	6
Contacts Configuration					
Rated current / voltage	10A 250V	10A 250V	10A 250V	10A 250V	10A 250V
Operating voltage limit (AC.V.rms)	400	400	400	400	300
Withstanding voltage (AC.V.rms) 1 minute	2000	2000	2000	1800	1800
Insulation resistance (MΩ MIN.) at DC 500V	2000	2000	2000	2000	2000
Contact resistance (mΩ MAX.) at DC 1A	3	3	3	3	3
Solder inter diameter	1.9	1.9	1.9	1.9	1.9

● 以上機種可設計防水型 Above models could be altered to waterproof types IP65 IP67 IP68

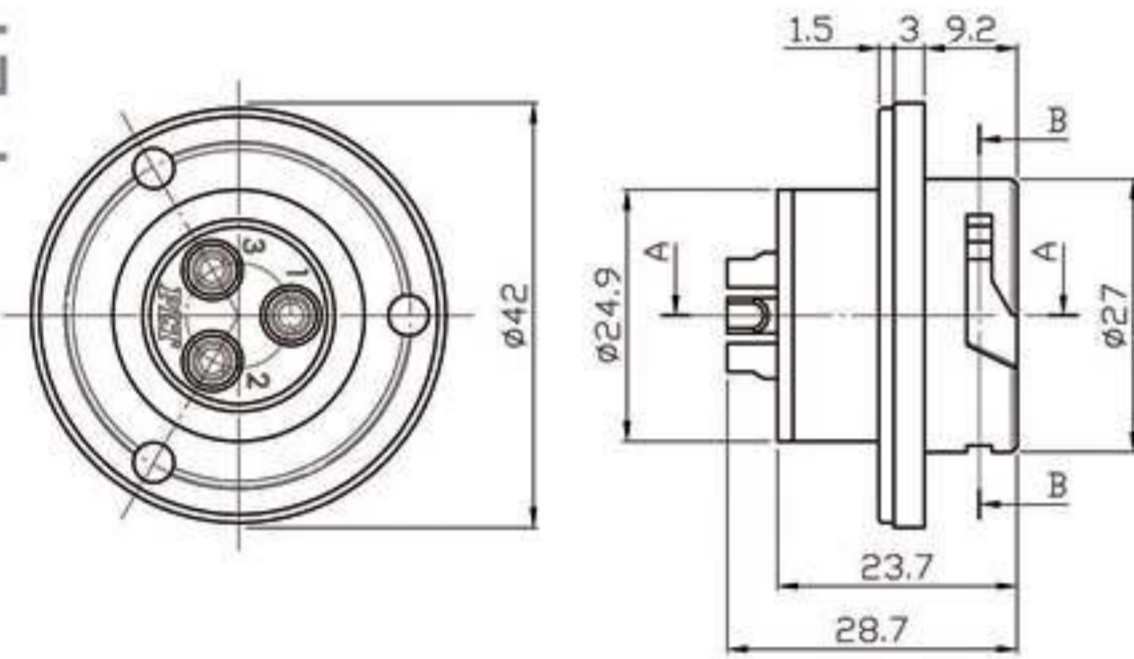

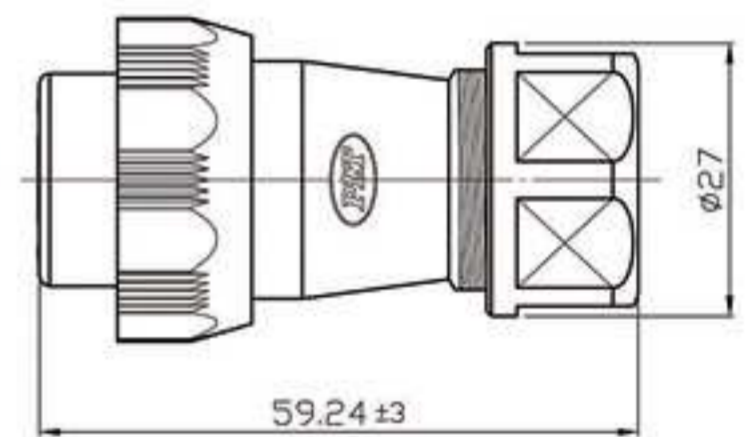
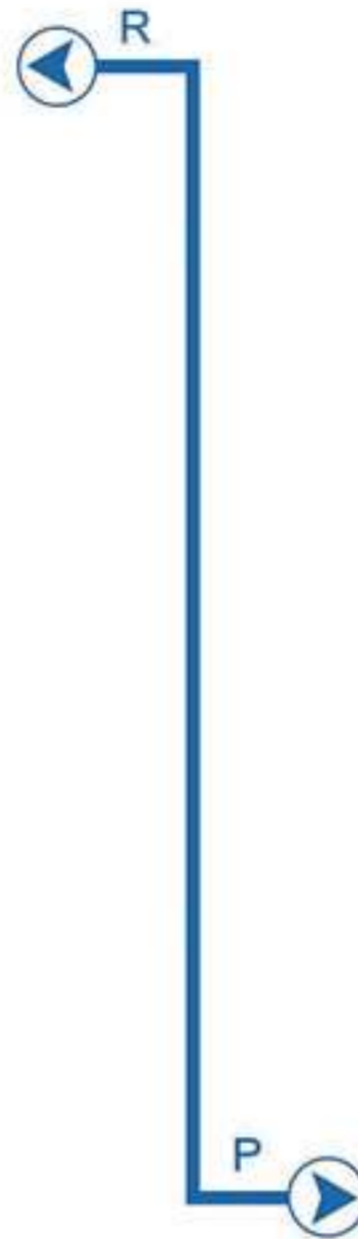

PLT-25◆A-R-R



PLT-25◆A-P-R

(Engineering Plastic 工程塑膠)

◆ No. of contacts	3	4			
Contacts Configuration					
Rated current / voltage	10A 250V	10A 250V			
Operating voltage limit (AC.V.rms)	200	200			
Withstanding voltage (AC.V.rms) 1 minute	1000	1000			
Insulation resistance (MΩ MIN.) at DC 500V	1000	1000			
Contact resistance (mΩ MAX.) at DC 1A	3	3			
Solder inter diameter					

另有鎖側螺絲選項
Optional accessory: side screws

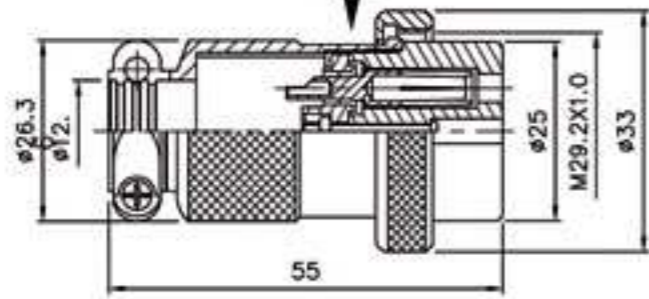
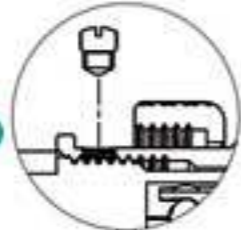

PLT-30-P-R

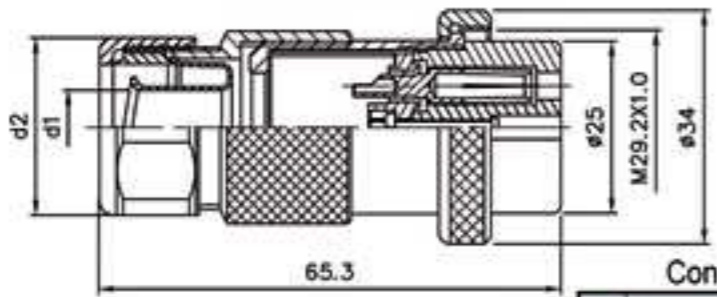

PLT-30-GP-R

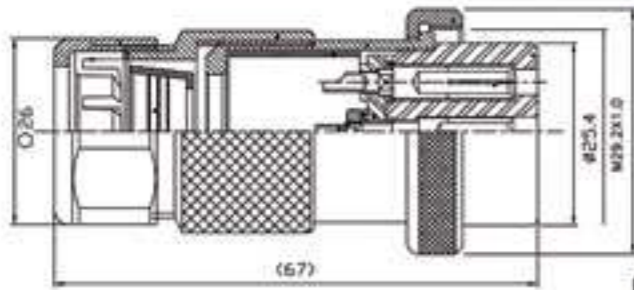

PLT-30-WGP-R

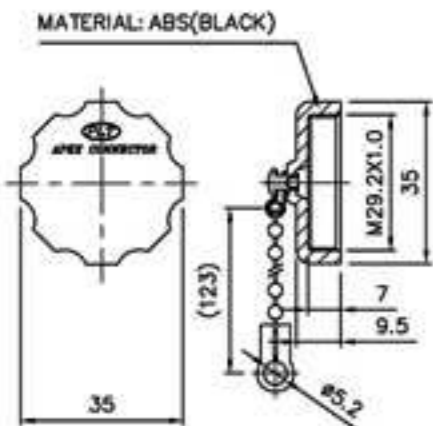

Material: Plastic
材質: 塑膠



Material: Zinc Alloy
材質: 鋅合金



Material: Plastic
材質: 塑膠

PAT PLT-30A-RCa-R

PLT-30C-RCa-R

PAT A-591PX

本件加值不加價
Value-Added with the Same Price



PLT-30 Series

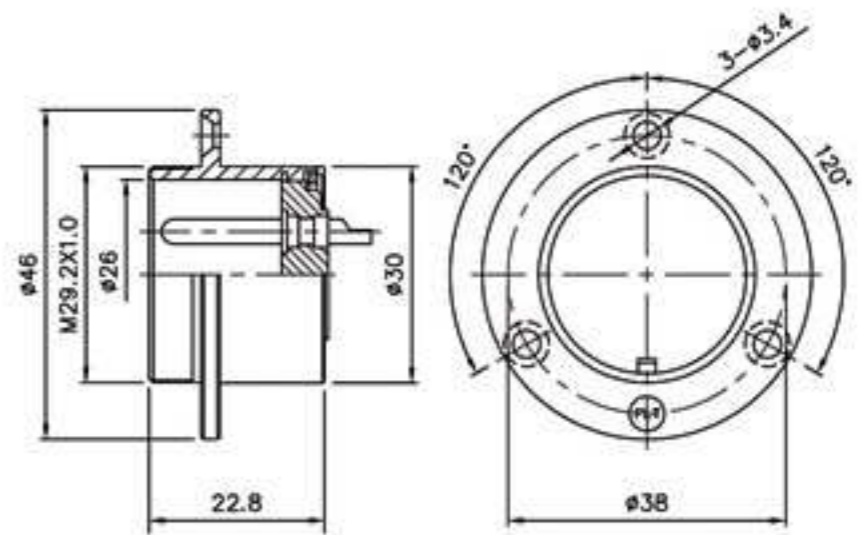

PLT-30-R-R

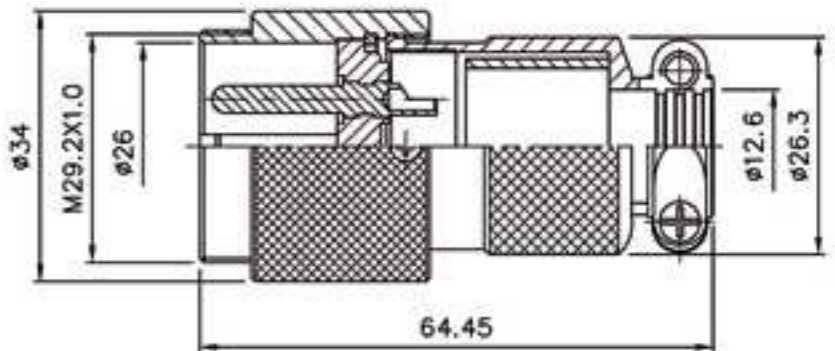

PLT-30-AD-R

No. of contacts	2	3	4	5	8
Contacts Configuration					
Rated current / voltage	15A 250V	15A 250V	15A 250V	15A 250V	10A 250V
Operating voltage limit (AC.V.rms)	400	400	400	400	300
Withstanding voltage (AC.V.rms) 1 minute	2000	2000	2000	1800	1800
Insulation resistance (MΩ MIN.) at DC 500V	2000	2000	2000	2000	2000
Contact resistance (mΩ MAX.) at DC 1A	3	3	3	3	3
Solder inter diameter	2.8	2.8	2.8	2.8	2.5

● 以上機種可設計防水型 Above models could be altered to waterproof types IP65 IP67 IP68

Output Type

PLT SERIES 2

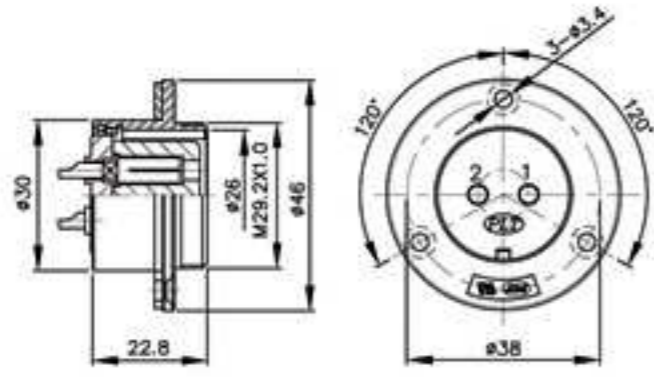

PLT-30-RF-R

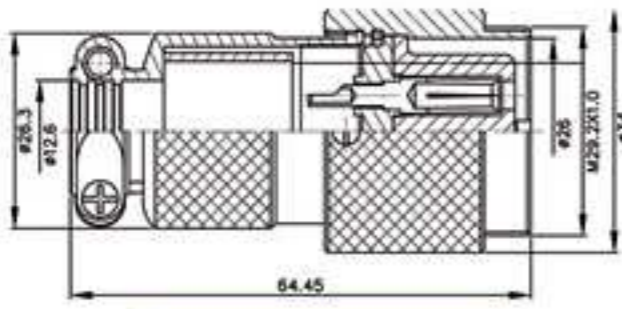

PLT-30-ADF-R

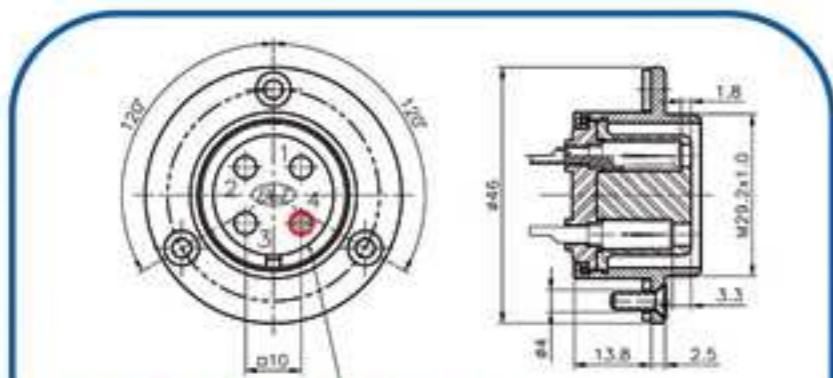

*註一：孔位4號為接地線
Note: position 4 is for earth wire

PAT PLT-304E-RF-R

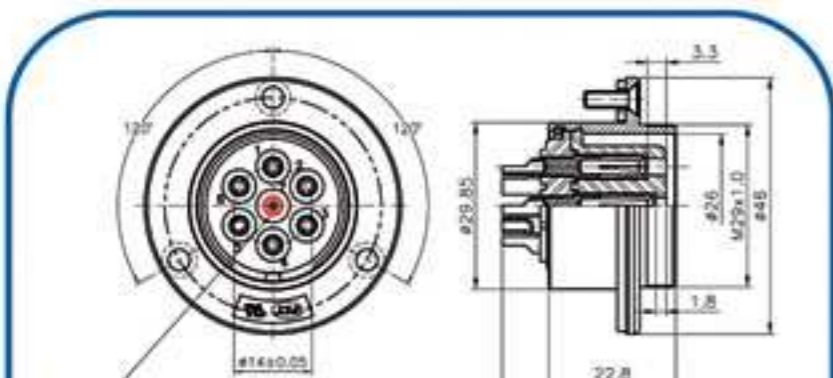

*註一：孔位7號為接地線
Note: position 7 is for earth wire

PAT PLT-307E-RF-R



PLT-30 Series

另有鎖側螺絲選項
Optional accessory: side screws

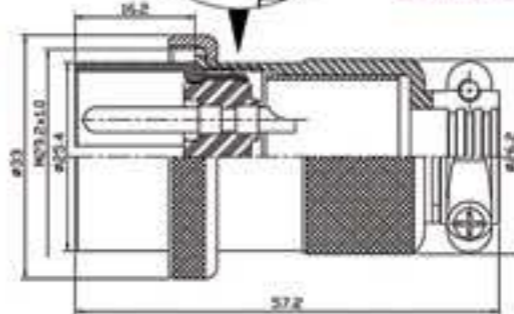

PLT-30-PM

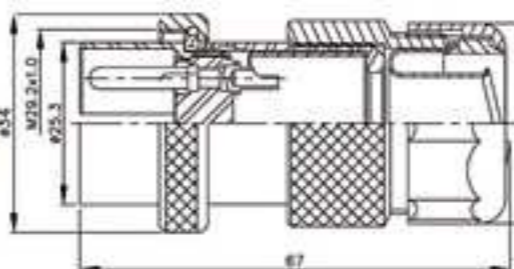

PLT-30-GPM

Conduit

3	3/8" 軟管	d1	d2
		ø10.8	ø26.3
4	1/2" 軟管	d1	d2
		ø14.3	ø31.2

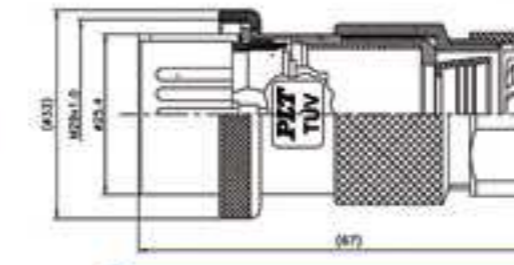

PLT-30-WGPM-R

Nylon Tube

3	3/8" 尼龍管	d1	d2
		ø10.8	ø26.3
4	1/2" 尼龍管	d1	d2
		ø14.3	ø31.2



Material: Plastic
材質: 塑膠



Material: Zinc Alloy
材質: 鋅合金

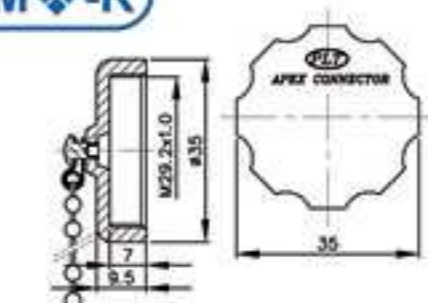

Material: Plastic
材質: 塑膠



PAT A-591PX

本件加值不加價
Value-Added with the Same Price

PLT-30C-RCa-R

PAT PLT-30A-RCa-R

No. of contacts	2	3	4	5	7	8
Contacts Configuration						
Rated current / voltage	15A 250V	15A 250V	15A 250V	15A 250V	15A 250V	10A 250V
Operating voltage limit (AC.V.rms)	400	400	400	400	400	300
Withstanding voltage (AC.V.rms) 1 minute	2000	2000	2000	1800	1800	1800
Insulation resistance (MΩ MIN.) at DC 500V	2000	2000	2000	2000	2000	2000
Contact resistance (mΩ MAX.) at DC 1A	3	3	3	3	3	3
Solder inter diameter	2.8	2.8	2.8	2.8	2	2.5

30

TÜV

Input Type

2
PLT SERIES

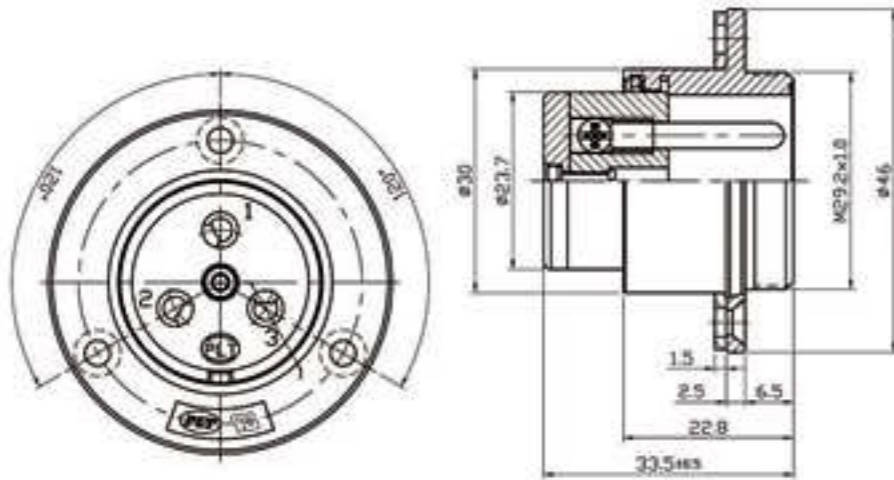

PAT PLT-303-RN-R



PLT-30 Series

另有鎖側螺絲選項
Optional accessory: side screws

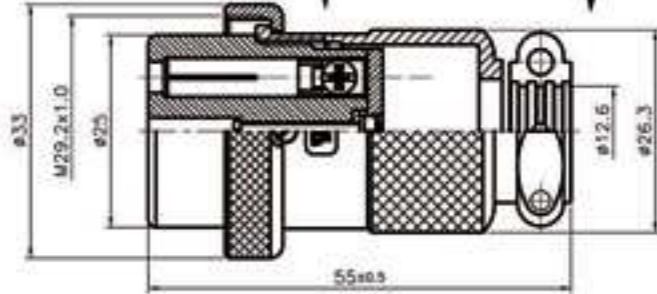
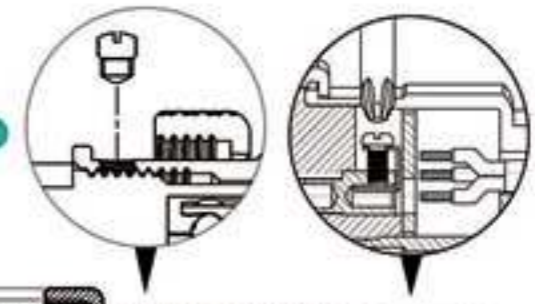

PAT PLT-303-PN-R

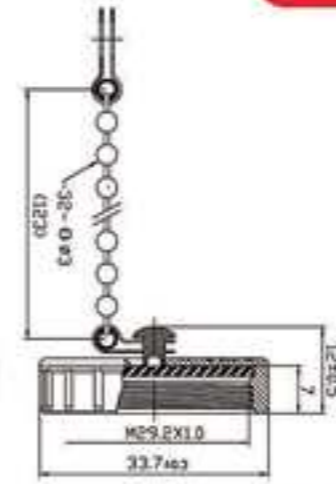

Material: Plastic
材質: 塑膠

Material: Zinc Alloy
材質: 鋅合金

Material: Plastic
材質: 塑膠



Screw-Lockup-Contact Model
螺絲鎖附型

Patent of invention, all rights reserved
專利產品、仿冒必究

PAT A-591PX

PLT-30C-RCa-R

PAT PLT-30A-RCa-R

本件加值不加價
Value-Added with the Same Price

No. of contacts	3				
Contacts Configuration	 TÜV				
Rated current / voltage	15A 250V				
Operating voltage limit (AC.V.rms)	400				
Withstanding voltage (AC.V.rms) 1 minute	2000				
Insulation resistance (MΩ MIN.) at DC 500V	2000				
Contact resistance (mΩ MAX.) at DC 1A	3				
Solder inter diameter	2.8				

● 以上機種可設計防水型 Above models could be altered to waterproof types IP65 IP67 IP68

PLT SERIES 2

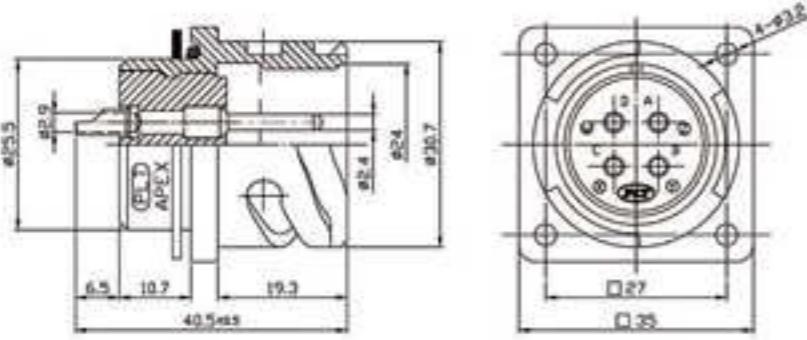

PLT3102A 18-10PA

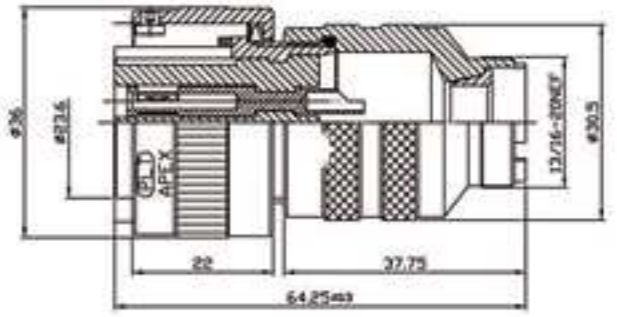
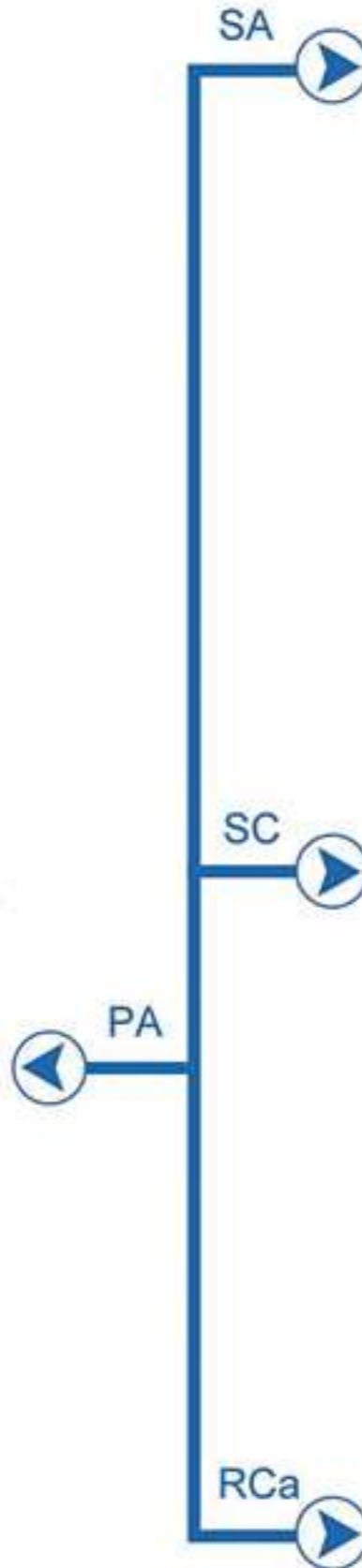

PLT3106A 18-10SA

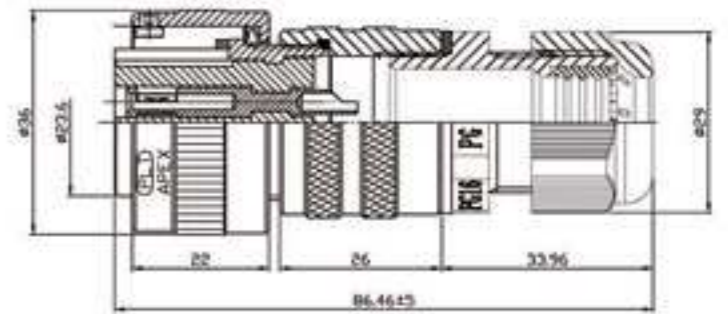

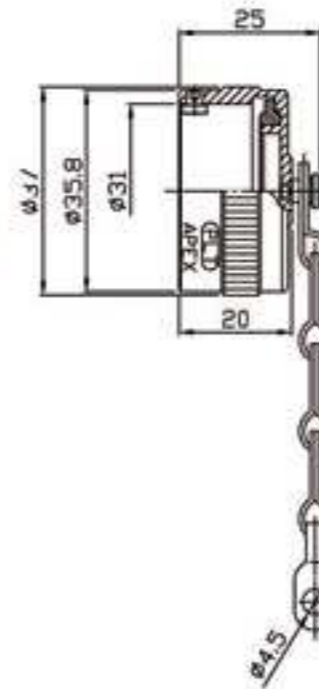

PLT3106A 18-10SC



PLT-18RCa

Material: Aluminum Alloy
材質: 鋁合金

 No. of contacts	4			
Contacts Configuration				
Operating Voltage	23A DC : 700V AC : 500V			
Withstanding voltage (AC.V.rms) 1 minute	2000			
Insulation resistance (MΩ MIN.) at DC 500V	5000			
Test Current	23			

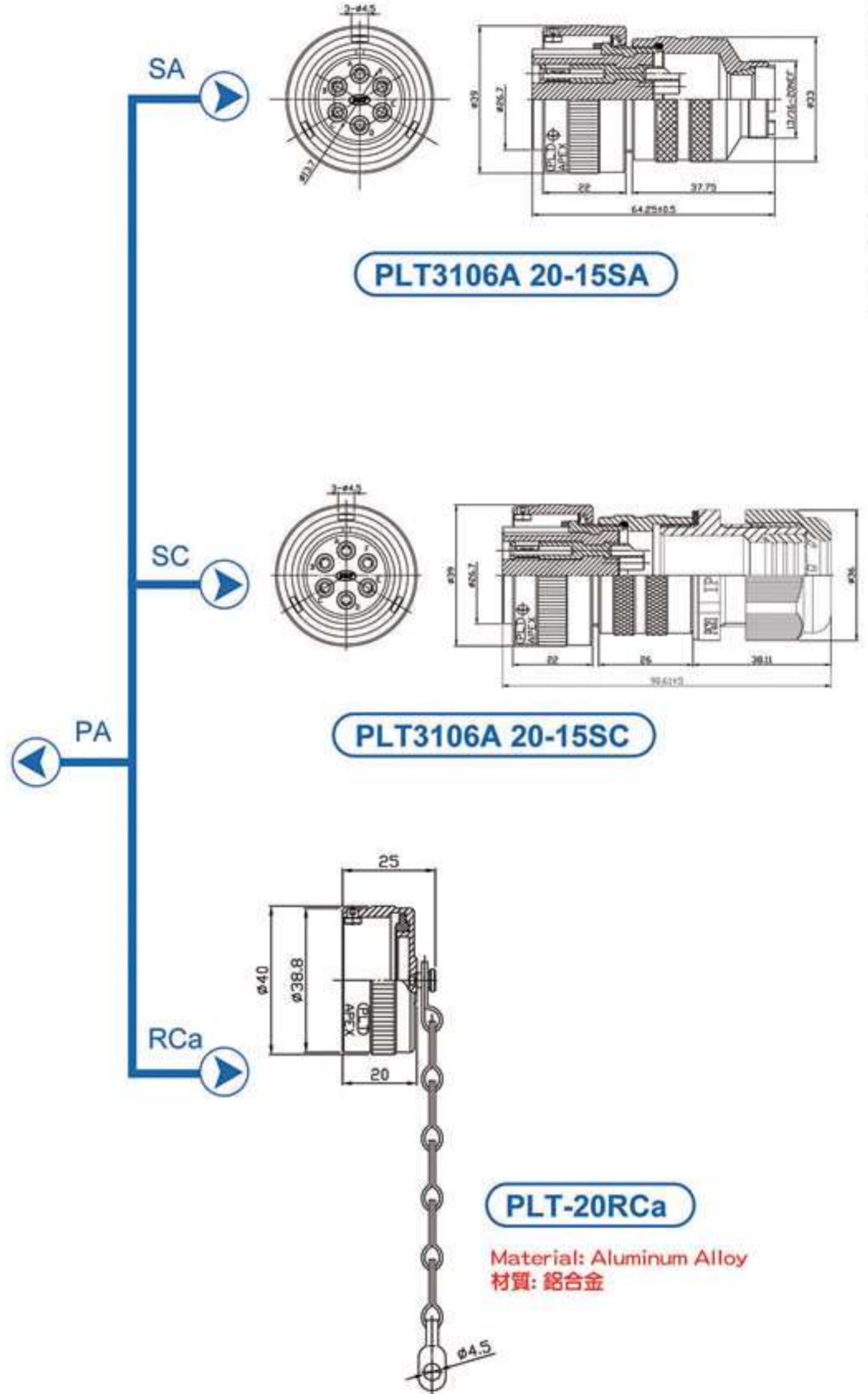
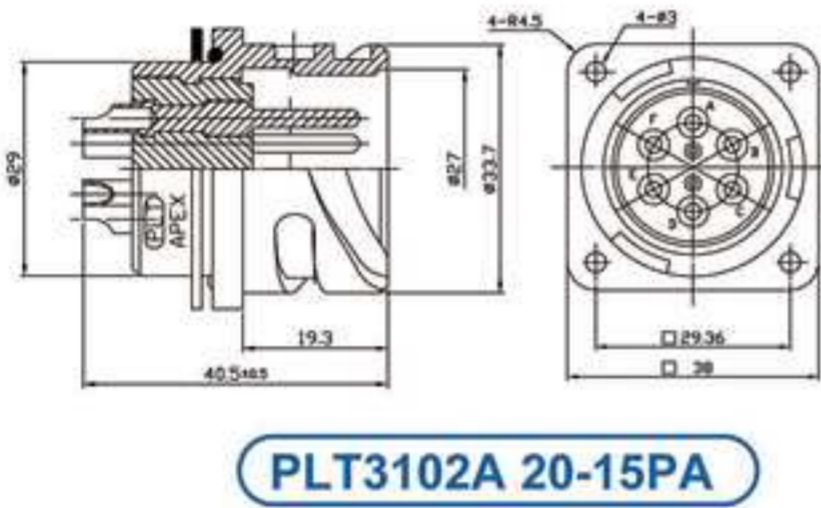

No. of contacts	6			
Contacts Configuration				
Operating Voltage	23A DC : 700V AC : 500V			
Withstanding voltage (AC.V.rms) 1 minute	2000			
Insulation resistance (MΩ MIN.) at DC 500V	5000			
Test Current	23			

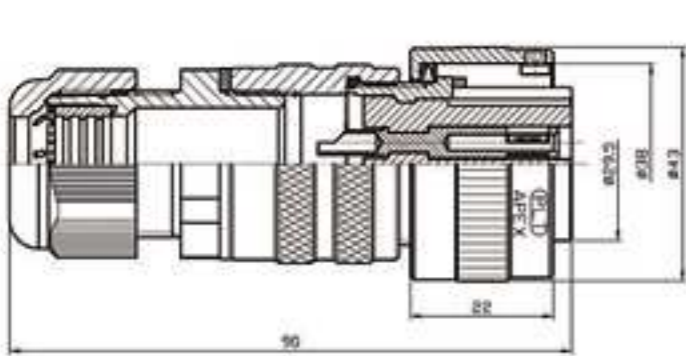

PLT3106A 22-22SC

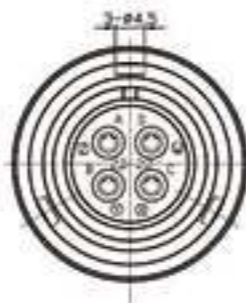

SC

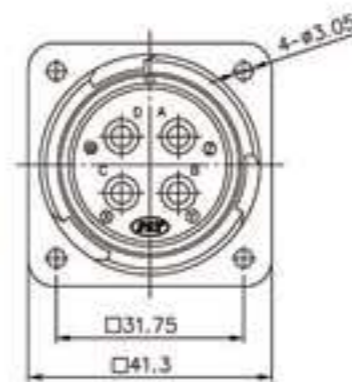

PLT3102A 22-22PA

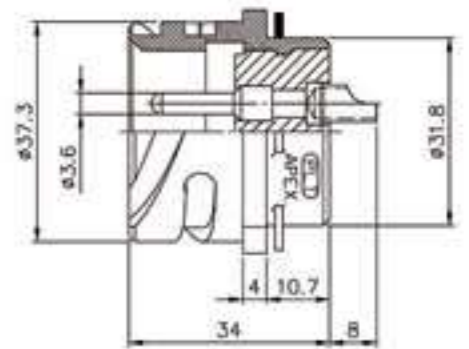

PA

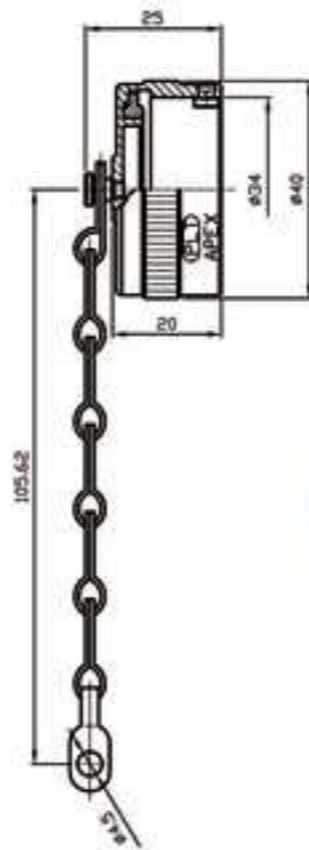

PLT-22RCa

RCa

Material: Aluminum Alloy
材質: 鋁合金

No. of contacts	4				
Contacts Configuration					
Operating Voltage	46A DC : 1250V AC : 900V				
Withstanding voltage (AC.V.rms) 1 minute	2000				
Insulation resistance (MΩ MIN.) at DC 500V	5000				
Test Current	23				

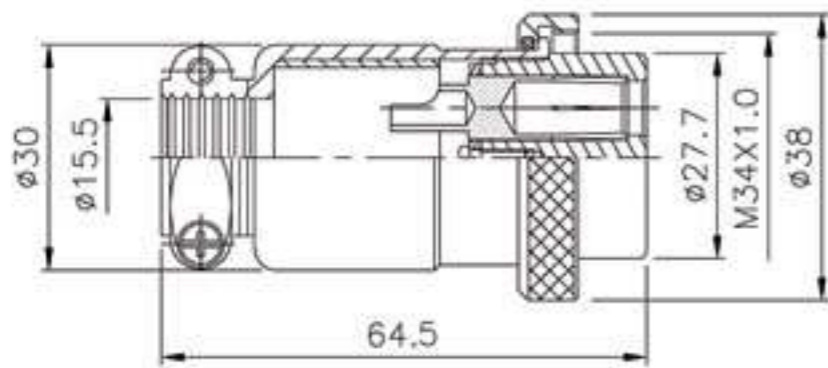

PLT-32-P-R



PLT-32 Series

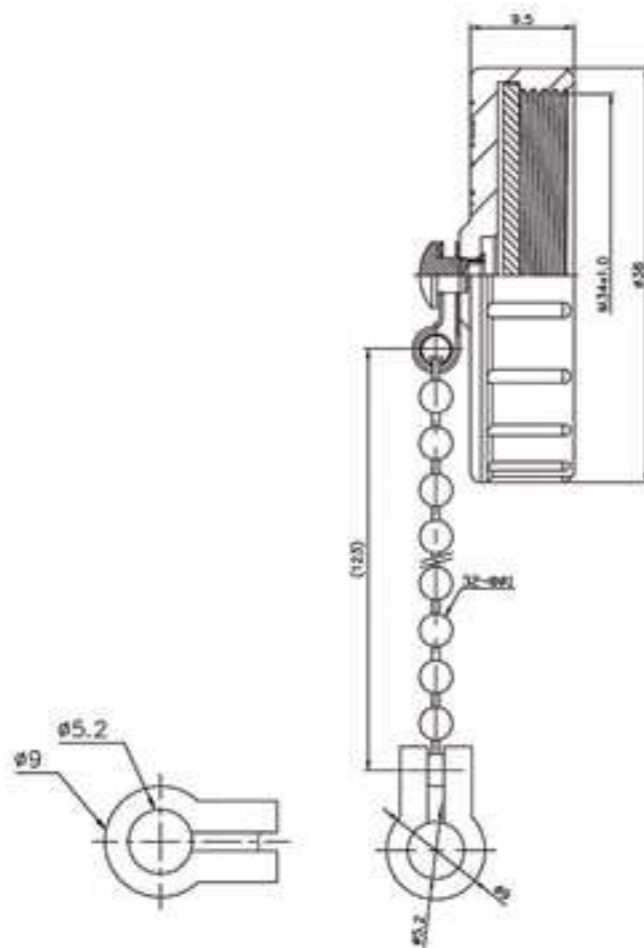

Material: Zinc Alloy
材質: 鋅合金





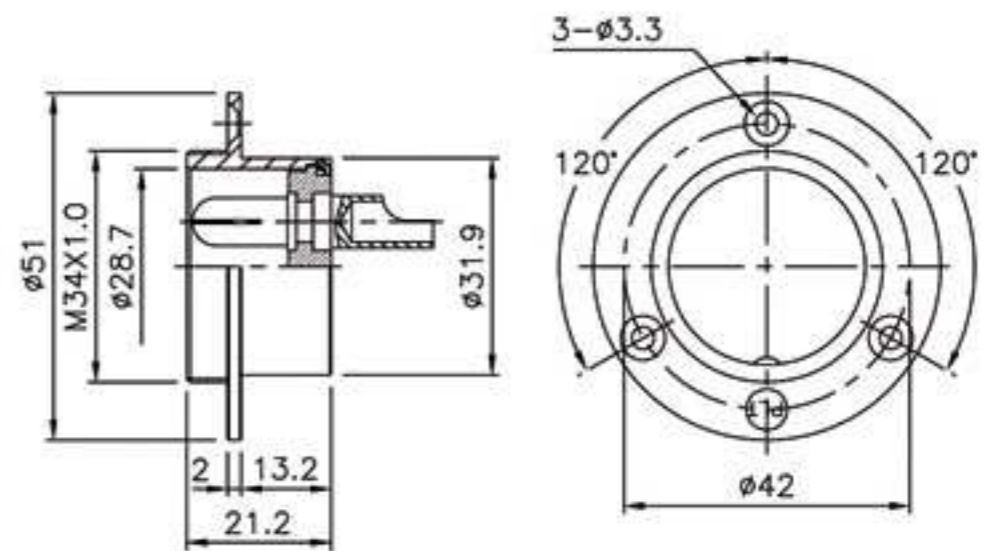
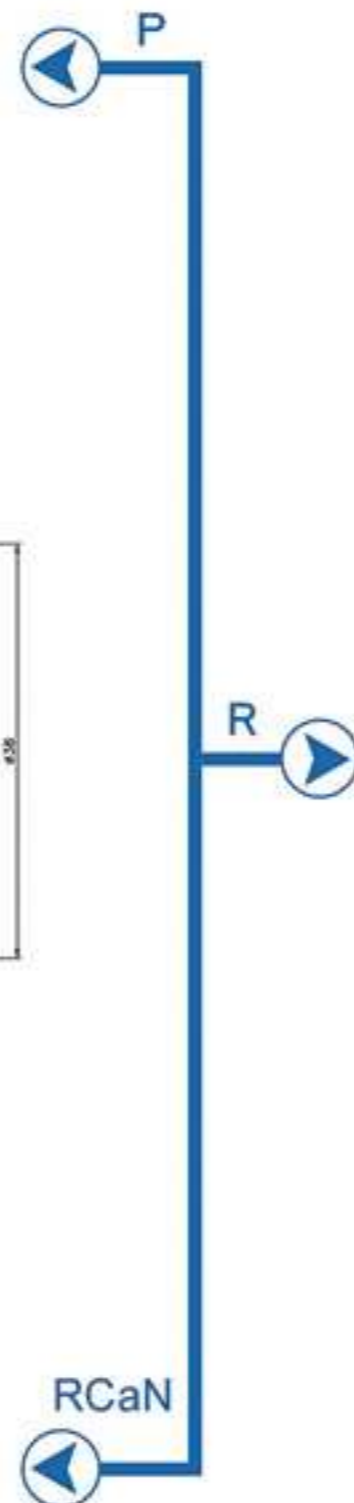

PLT-32C-RCaN-R



PLT-32-R-R

Finish (表面處理) →
 Nickel-plated / 鍍鎳
 Chrome-plated / 鍍鉻

◆ No. of contacts	2	3			
Contacts Configuration	 TÜV 	 TÜV 			
Rated current / voltage	30A 250V	30A 250V			
Operating voltage limit (AC.V.rms)	400	400			
Withstanding voltage (AC.V.rms) 1 minute	2000	2000			
Insulation resistance (MΩ MIN.) at DC 500V	2000	2000			
Contact resistance (mΩ MAX.) at DC 1A	5	5			
Solder inter diameter	6	6			

Input Type

PLT SERIES 2

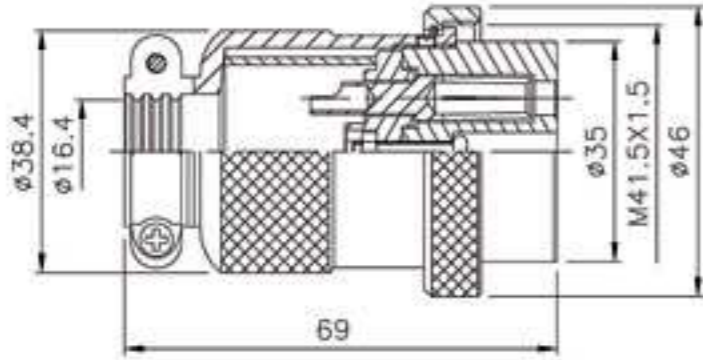

PLT-40-P-R



PLT-40 Series

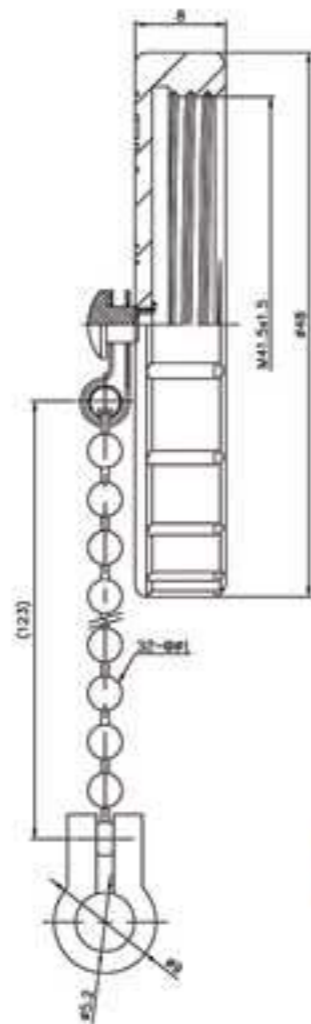



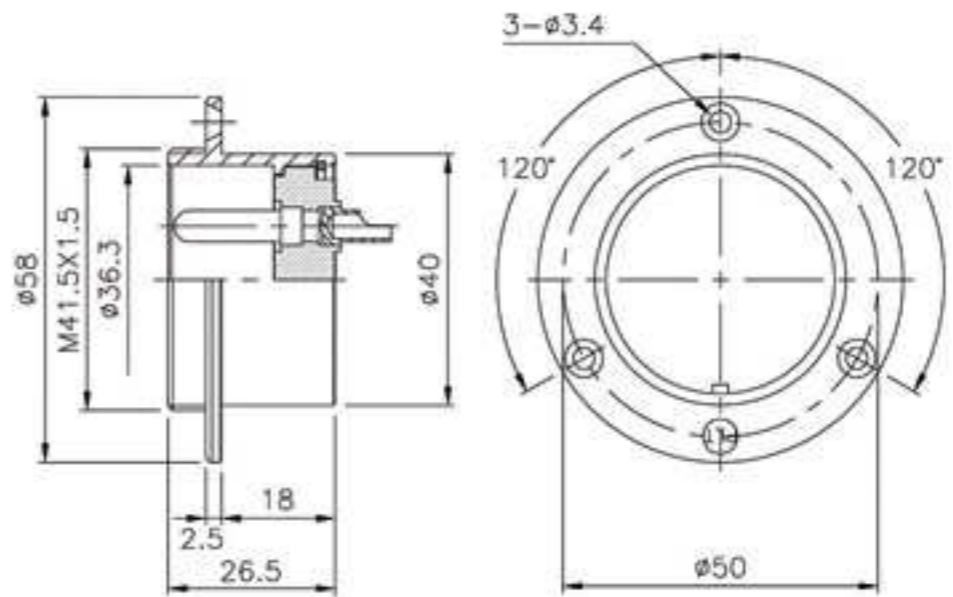



PLT-40-R-R



PLT-40C-RCaC-R

Material: Zinc Alloy
材質: 鋅合金

◆ No. of contacts	4	8	37			
Contacts Configuration	 TÜV 	 TÜV 	 TÜV 			
Rated current / voltage	30A 250V	20A 250V	5A 300V			
Operating voltage limit (AC.V.rms)	500	400	300			
Withstanding voltage (AC.V.rms) 1 minute	2500	2000	1000			
Insulation resistance (MΩ MIN.) at DC 500V	2000	2000	1800			
Contact resistance (mΩ MAX.) at DC 1A	3	3	3			
Solder inter diameter	4	4.8	1.9			

40

TÜV

Output Type

2
PLT SERIES

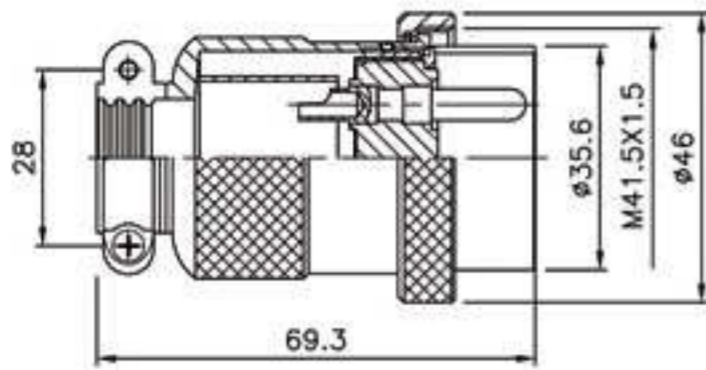

PLT-40-PM-R



PLT-40 Series

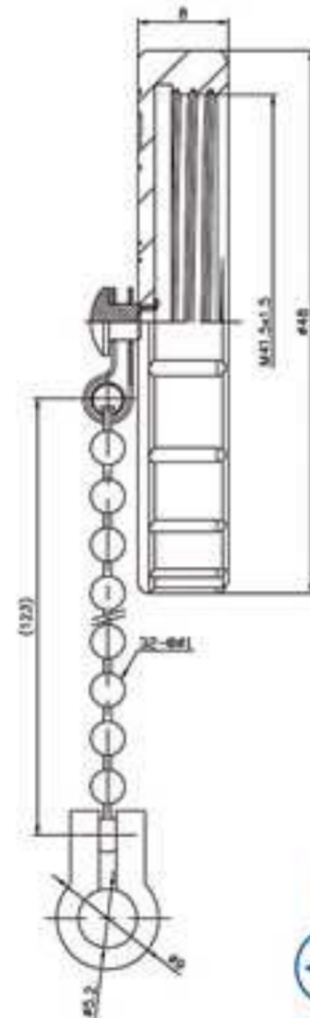

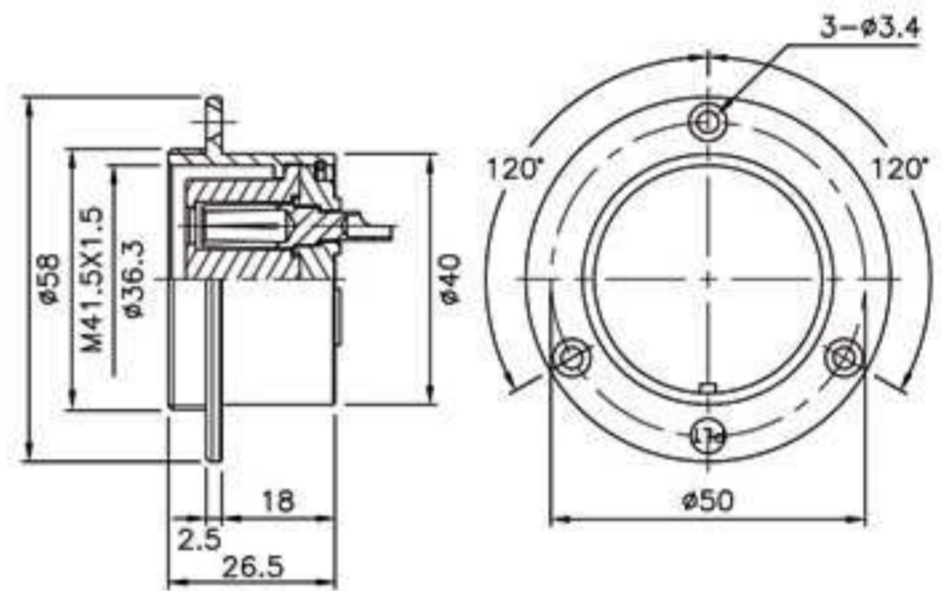

PLT-40C-RCaC-R

Material: Zinc Alloy
材質: 鋅合金



PLT-40-RF-R

No. of contacts	4	37			
Contacts Configuration	 TÜV	 TÜV			
Rated current / voltage	30A 250V	5A 300V			
Operating voltage limit (AC.V.rms)	500	200			
Withstanding voltage (AC.V.rms) 1 minute	2500	1000			
Insulation resistance (MΩ MIN.) at DC 500V	2000	1800			
Contact resistance (mΩ MAX.) at DC 1A	3	3			
Solder inter diameter	4	1.9			

● 以上機種可設計防水型 Above models could be altered to waterproof types 

Input Type

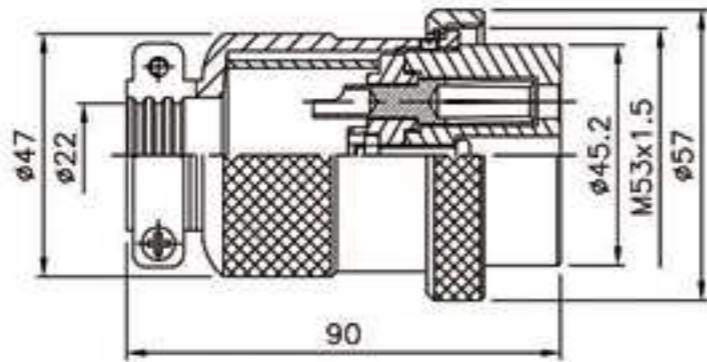

PLT-50-P



PLT- 50 Series

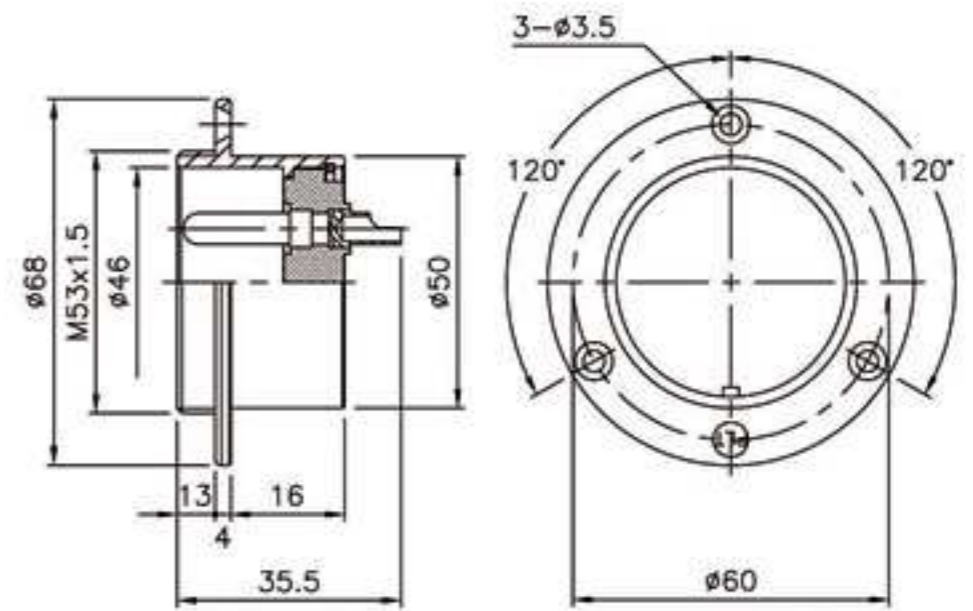

PLT-50-R

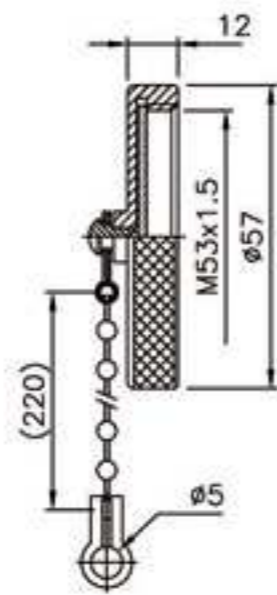

PLT-50-RCa

No. of contacts	4				
Contacts Configuration					
Rated current / voltage	80A 250V				
Operating voltage limit (AC.V.rms)	600				
Withstanding voltage (AC.V.rms) 1 minute	3000				
Insulation resistance (MΩ MIN.) at DC 500V	5000				
Contact resistance (mΩ MAX.) at DC 1A	3				
Solder inter diameter					



PLK-16 Series



PLK-30 Series



WGP
防水電氣配管
Liquid-Tight Conduits



GP
防水防爆電氣配管
Explosionproof Liquid-Tight
Conduits



CG
耐扭式電纜固定頭
Flex Protective Cable Glands



● ORDERING INFORMATION

PLK-162-P-R



P	Plug	插頭	AD	Adapter	中繼
R	Receptacle	插座	Ca	Cap	保護蓋
F	Female	導梢	RT	Rubber tube	橡膠管
M	Male	導針	GP	Conduit type	軟管式
WGP	Nylon type	尼龍管式	CG	Cable glands	迫緊頭
LP	Shape	L型90°	RL	Single thread	單牙

● MATERIAL & FINISH

Kindly instruct material & finish by below types when ordering

Description	Material	Finish
Shell/外殼、本體	<ul style="list-style-type: none"> • Stainless Steel/不鏽鋼 • Zinc Die-Casting/鋅合金壓鑄 • Aluminum alloy/鋁合金壓鑄 	<ul style="list-style-type: none"> • Chrome-plated/鍍鉻 • Gold-plated/鍍金 • Nickel-plated/鍍鎳 • Silver-plated/鍍銀
Insulator/絕緣體	<ul style="list-style-type: none"> • Bakelite/電木 • Delrin/塑鋼 • Teflon/鐵氟龍 	
Contact/接觸體	<ul style="list-style-type: none"> • Brass/銅 • Phosphor bronze/磷青銅 • Beryllium copper/鈹銅 	<ul style="list-style-type: none"> • Gold-plated/鍍金 • Nickel-plated/鍍鎳 • Silver-plated/鍍銀

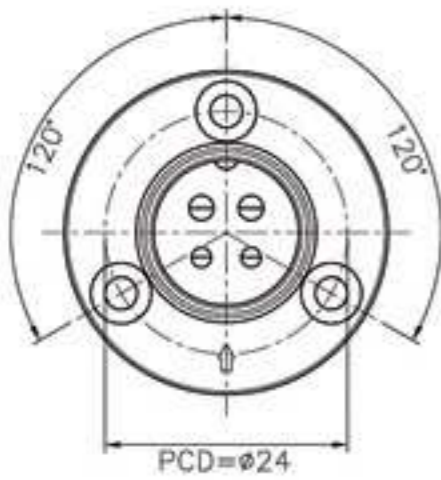

PLK-164-RA-R

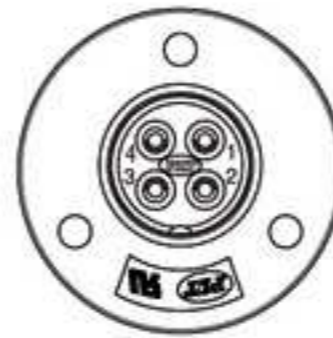
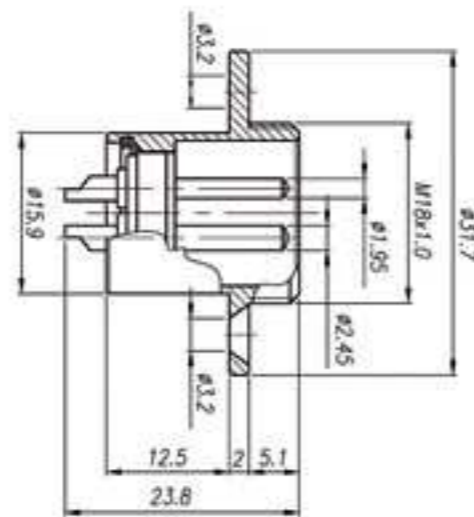

另有鎖側螺絲選項
Optional accessory: side screws

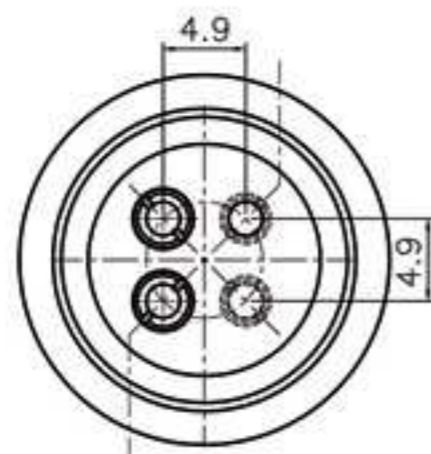

PLK-164-PA-R

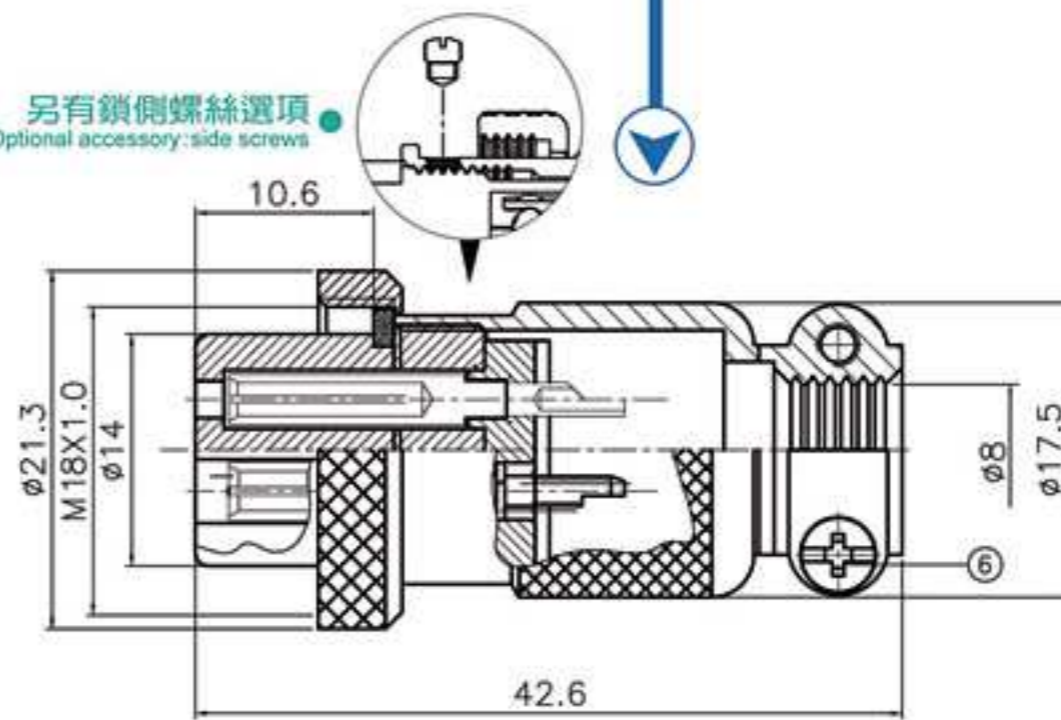

No. of contacts	4				
Contacts Configuration	 TUV				
Rated current / voltage	5A 125V				
Operating voltage limit (AC.V.rms)	200				
Withstanding voltage (AC.V.rms) 1 minute	1000				
Insulation resistance (MΩ MIN.) at DC 500V	1000				
Contact resistance (mΩ MAX.) at DC 1A	3				

● 以上機種可設計防水型 Above models could be altered to waterproof types



Input Type

PLK SERIES 3

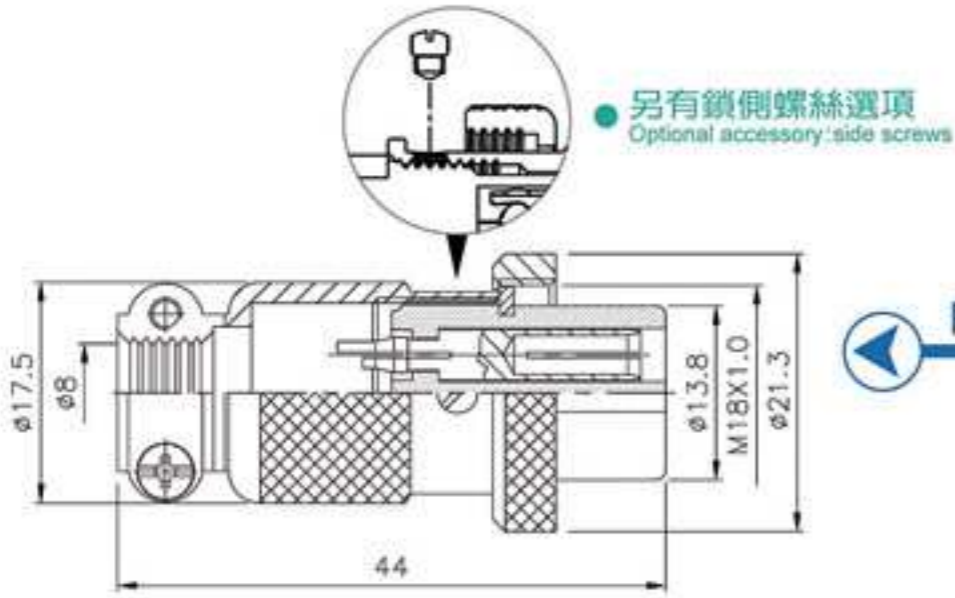

PLK-16-P-R



PLK-16 Series

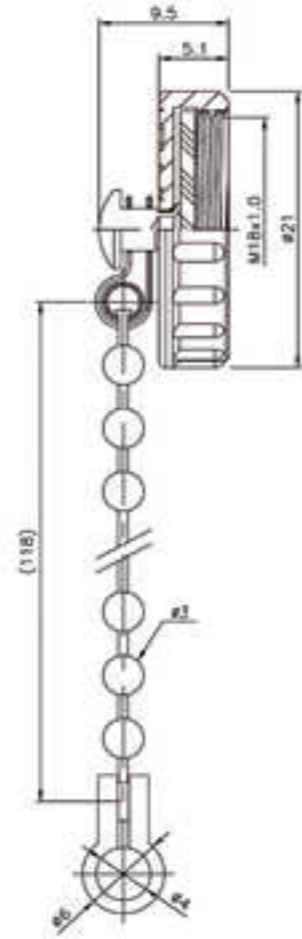

PLK-16-R-R

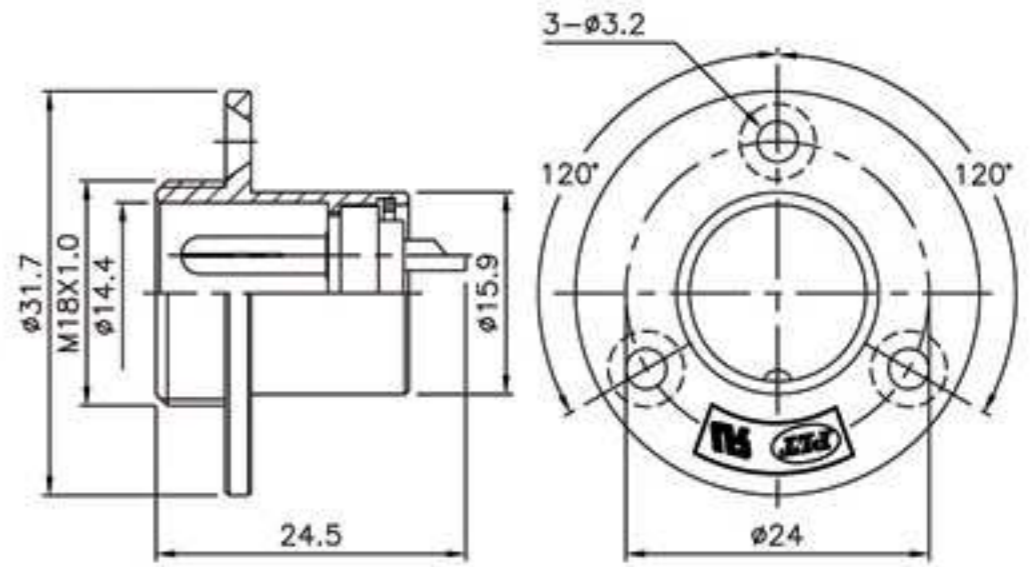

PLK-16C-RCaC-R

RCaC

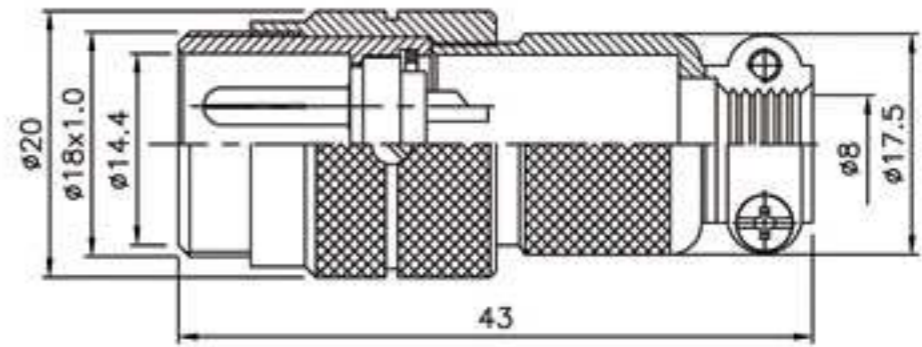

PLK-16-AD-R



◆ No. of contacts	2	3	4	5		
Contacts Configuration	 TUV	 TUV	 TUV	 TUV		
Rated current / voltage	5A 125V	5A 125V	5A 125V	5A 125V		
Operating voltage limit (AC.V.rms)	200	200	200	200		
Withstanding voltage (AC.V.rms) 1 minute	1000	1000	1000	1000		
Insulation resistance (MΩ MIN.) at DC 500V	1000	1000	1000	1000		
Contact resistance (mΩ MAX.) at DC 1A	3	3	3	3		
Solder inter diameter	1.5	1.5	1.5	1.3		



另有鎖側螺絲選項
Optional accessory: side screws

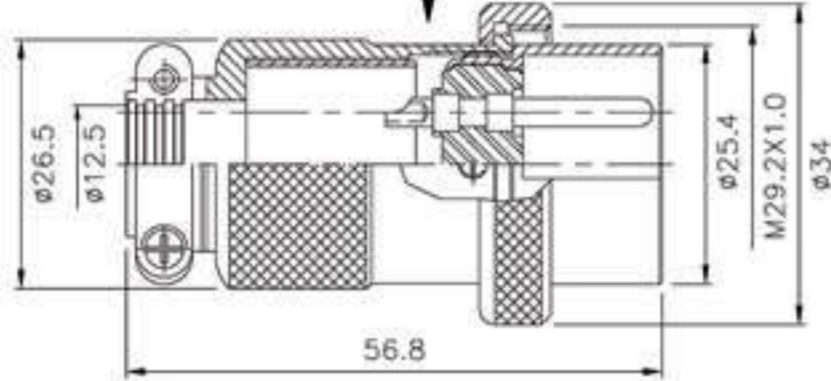

PLK-30-PM-R

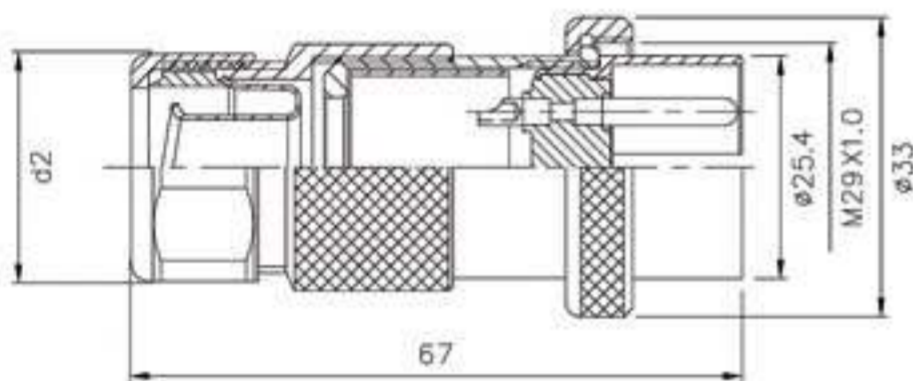

PLK-30-GPM-R

Conduit			
3	3/8" 軟管	d1 ø10.8	d2 ø26.3
4	1/2" 軟管	d1 ø14.3	d2 ø31.2

MATERIAL: ABS(BLACK)

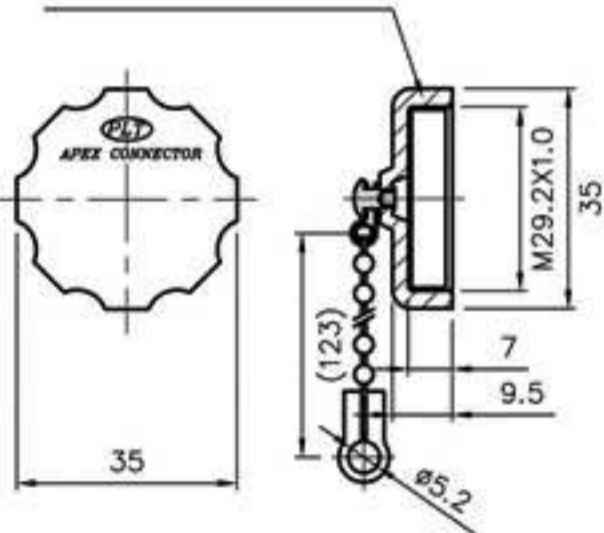

Material: Plastic
材質: 塑膠



PAT PLT-30A-RCa-R

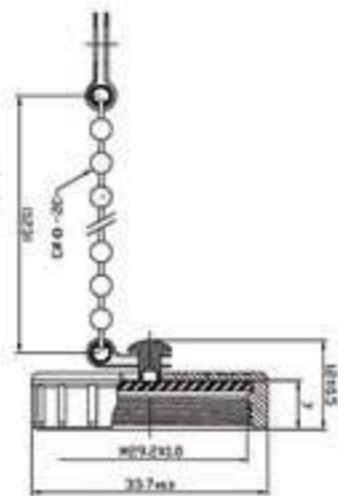

Material: Zinc Alloy
材質: 鋅合金



PLT-30C-RCa-R



Material: Plastic
材質: 塑膠

PAT A-591PX

本件加值不加價
Value-Added with the Same Price



PLK-30 Series

3
PLK SERIES

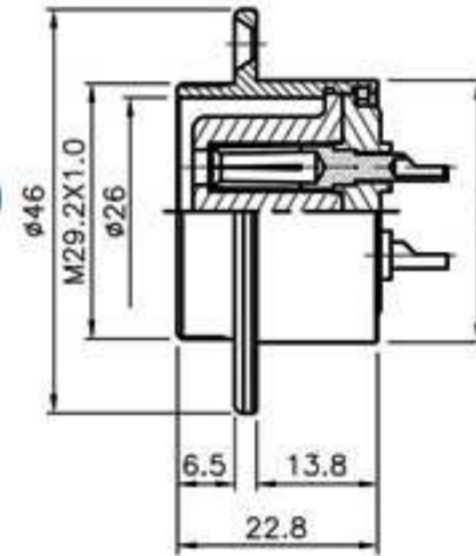

PLK-30-RF-R

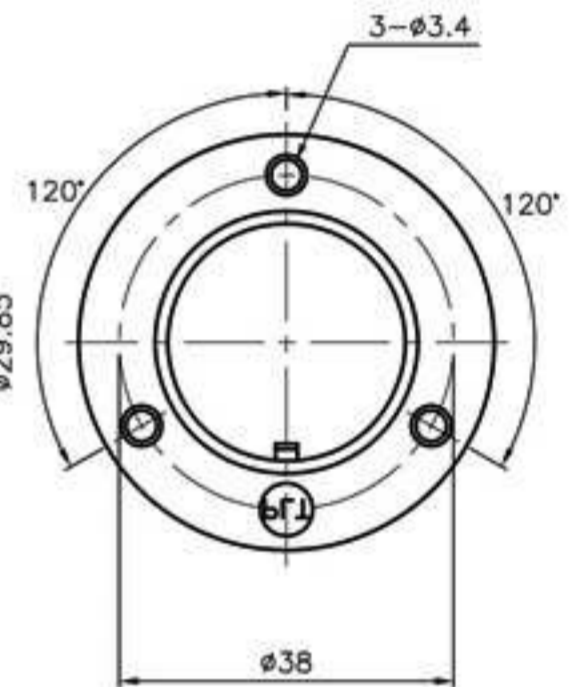

◆ No. of contacts	4	7			
Contacts Configuration					
Rated current / voltage	15A 250V	15A 250V			
Operating voltage limit (AC.V.rms)	400	400			
Withstanding voltage (AC.V.rms) 1 minute	2000	1800			
Insulation resistance (MΩ MIN.) at DC 500V	2000	2000			
Contact resistance (mΩ MAX.) at DC 1A	3	3			
Solder inter diameter	3.5	3			

● 以上機種可設計防水型 Above models could be altered to waterproof types IP65 IP67 IP68



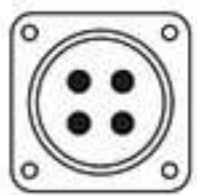

PLS-20 Series



PLS-24 Series



PLS-27 Series



PLS-28 Series



(Stainless Steel 不鏽鋼)

PLS-28 Series



PLS-35 Series



PLS-41 Series



PLS-4207 Series



WGP

防水電氣配管
Liquid-Tight Conduits



GP

防水防爆電氣配管
Explosionproof Liquid-Tight
Conduits



CG

耐扭式電纜固定頭
Flex Protective Cable Glands



● **ORDERING INFORMATION**

PLS-202-PM X-R



P	Plug	插頭	AD	Adapter	中繼
R	Receptacle	插座	Ca	Cap	保護蓋
F	Female	導梢	RT	Rubber tube	橡膠管
M	Male	導針	GP	Conduit type	軟管式
WGP	Nylon type	尼龍管式	CG	Cable glands	迫緊頭
LP	Shape	L型90°	RL	Single thread	單牙

● **MATERIAL & FINISH**

Kindly instruct material & finish by below types when ordering

Description	Material	Finish
Shell/外殼、本體	<ul style="list-style-type: none"> • Stainless Steel/不鏽鋼 • Zinc Die-Casting/鋅合金壓鑄 • Aluminum alloy/鋁合金壓鑄 	<ul style="list-style-type: none"> • Chrome-plated/鍍鉻 • Gold-plated/鍍金 • Nickel-plated/鍍鎳 • Silver-plated/鍍銀
Insulator/絕緣體	<ul style="list-style-type: none"> • Bakelite/電木 • Delrin/塑鋼 • Teflon/鐵氟龍 	
Contact/接觸體	<ul style="list-style-type: none"> • Brass/銅 • Phosphor bronze/磷青銅 • Beryllium copper/鈹銅 	<ul style="list-style-type: none"> • Gold-plated/鍍金 • Nickel-plated/鍍鎳 • Silver-plated/鍍銀



Input Type

PLS SERIES 4

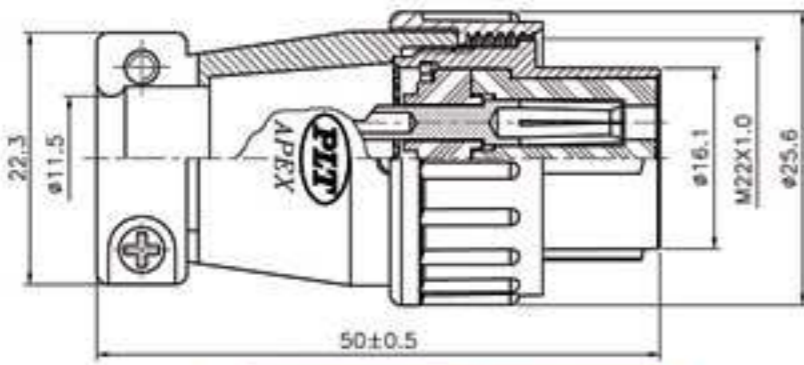

PLS-20-PF X-R

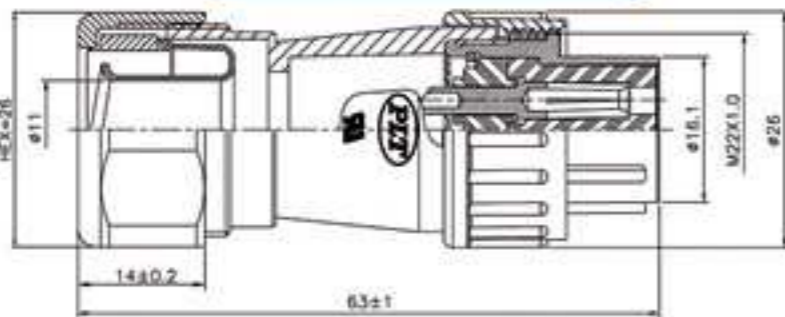

PLS-20-GPF3 X-R 3=轉接3/8"軟管
Connected with 3/8"conduit

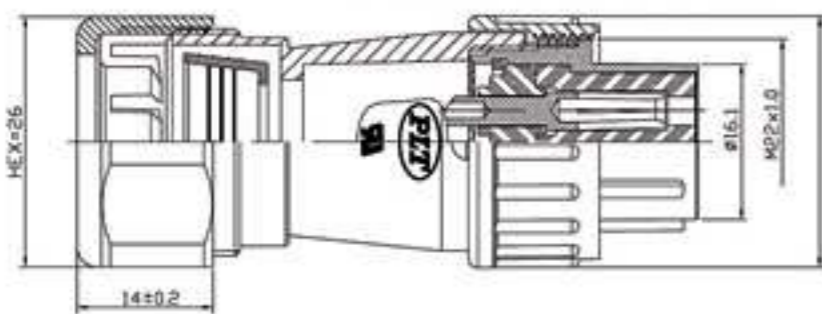

PLS-20-WGPF3 X-R 3=轉接3/8"尼龍管
Connected with 3/8"nylon tube



Material: Zinc Alloy
材質: 鋅合金

PLS-20C-RCaC-R

ACCESSORY:

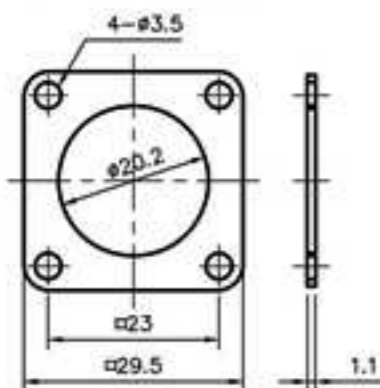

RUBBER GASKET FOR PLS-20-RM

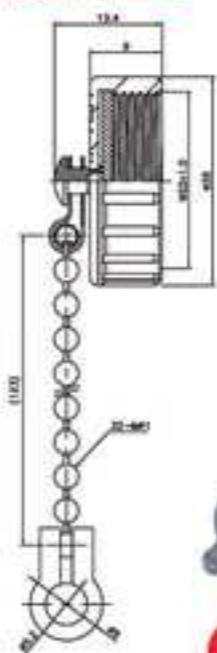

Material: Plastic
材質: 塑膠

PAT A-587PX

本件加值不加價
Value-Added with the Same Price

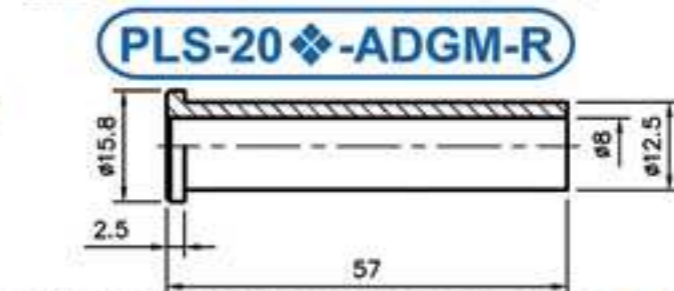

RUBBER TUBE FOR PLS-20-PF



PLS- 20 Series

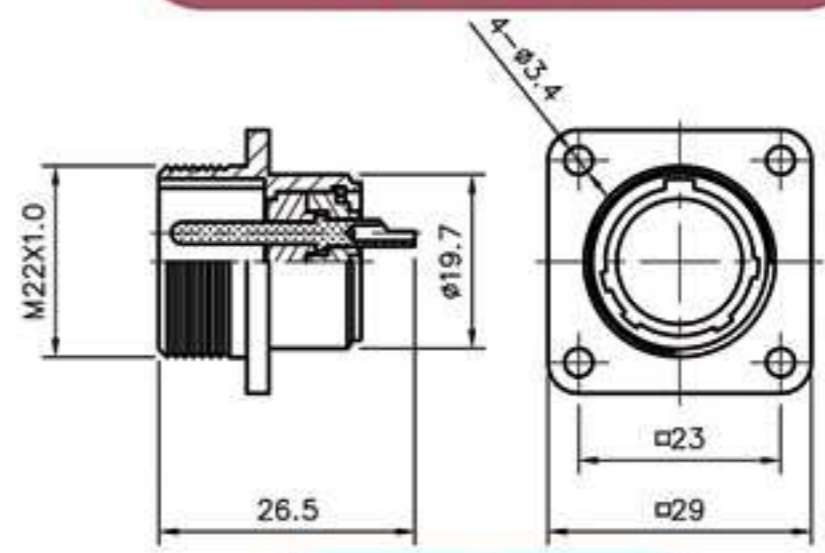

PLS-20-RM-R

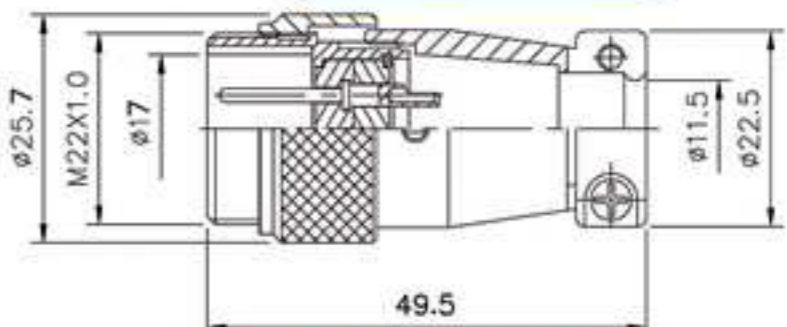

PLS-20-ADM-R

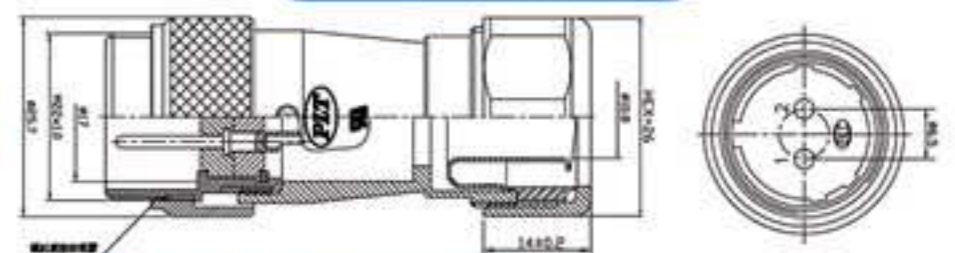

PLS-20-ADGM-R

No. of contacts	2	3	4	7
Contacts Configuration				
Rated current / voltage	15A 250V	15A 250V	10A 250V	10A 250V
Operating voltage limit (AC.V.rms)	250	250	250	250
Withstanding voltage (AC.V.rms) 1 minute	1500	1500	1000	1000
Insulation resistance (MΩ MIN.) at DC 500V	2000	2000	2000	2000
Contact resistance (mΩ MAX.) at DC 1A	3	3	3	3
Solder inter diameter	1.8	1.8	1.6	1.6



Output Type

4
PLS SERIES



PLS-20 Series

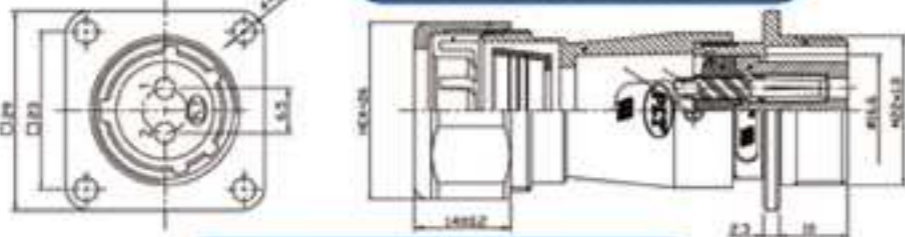
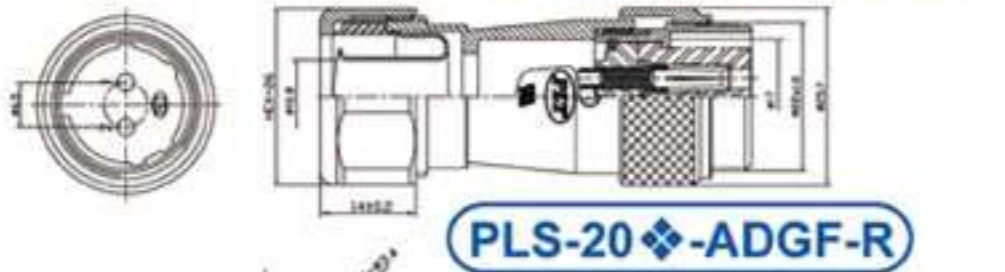
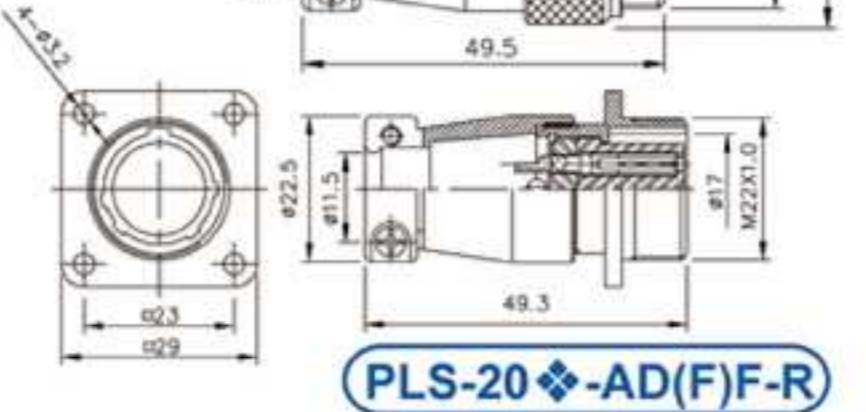
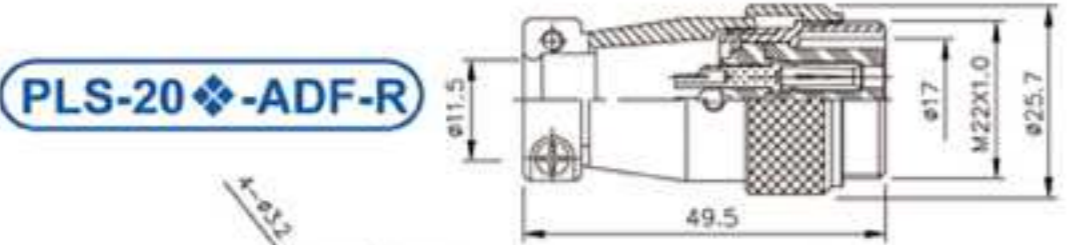
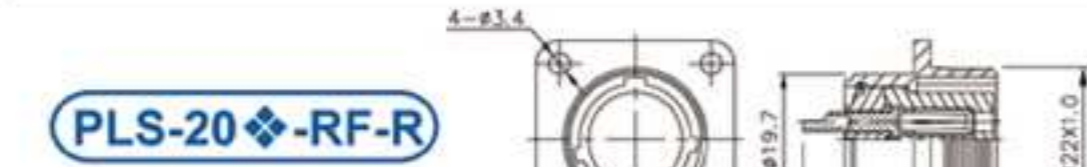

ACCESSORY:

RUBBER TUBE FOR PLS-20◆-PM

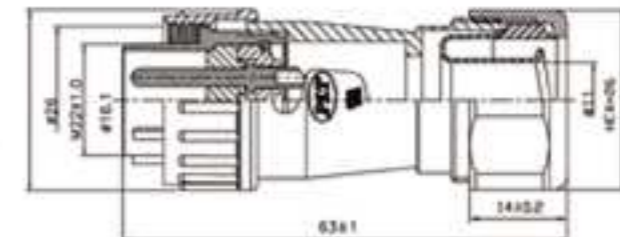
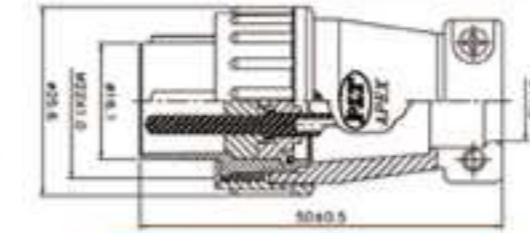

3=轉接3/8"軟管
Connected with 3/8"conduit

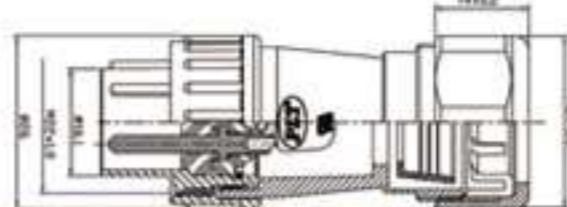

3=轉接3/8"尼龍管
Connected with 3/8"nylon tube



RUBBER GASKET FOR PLS-20◆-RF

DEVELOPING
開發中

★ NEW

◆ No. of contacts	2	3	4	5	7	12
Contacts Configuration						
Rated current / voltage	15A 250V	15A 250V	10A 250V	10A 250V	10A 250V	5A 250V
Operating voltage limit (AC.V.rms)	250	250	250	250	250	250
Withstanding voltage (AC.V.rms) 1 minute	1500	1500	1500	1500	1000	1000
Insulation resistance (MΩ MIN.) at DC 500V	2000	2000	2000	2000	2000	1000
Contact resistance (mΩ MAX.) at DC 1A	3	3	3	3	3	5
Solder inter diameter	1.8	1.8	1.6	1.6	1.6	1.2

● 以上機種可設計防水型 Above models could be altered to waterproof types





Input Type

PLS SERIES 4



PLS- 24 Series

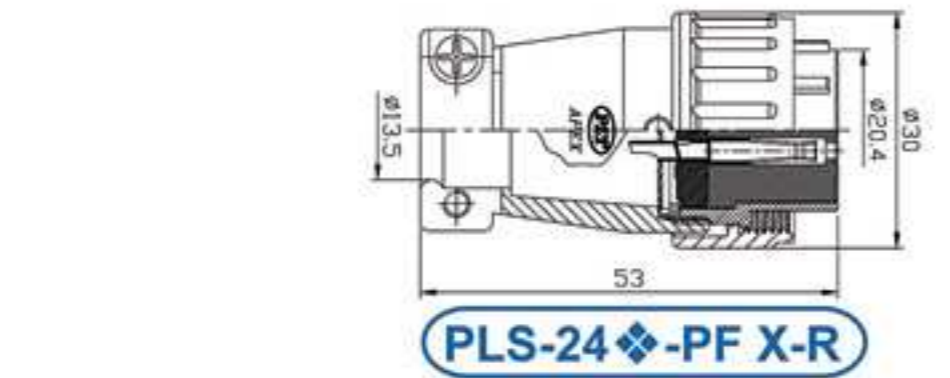

PF

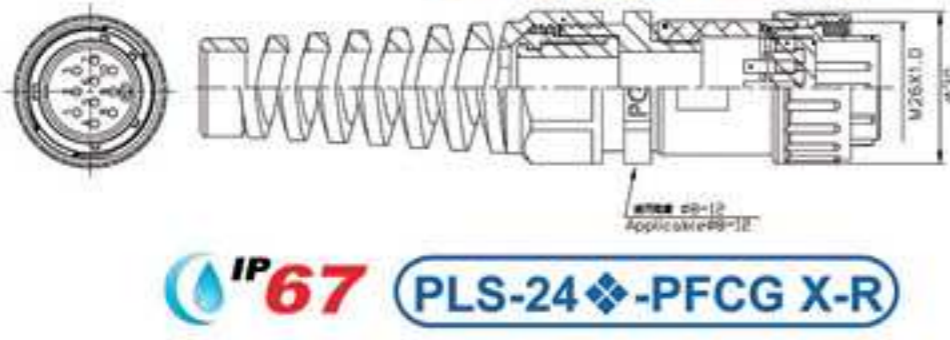

PFCG



GPF

RM

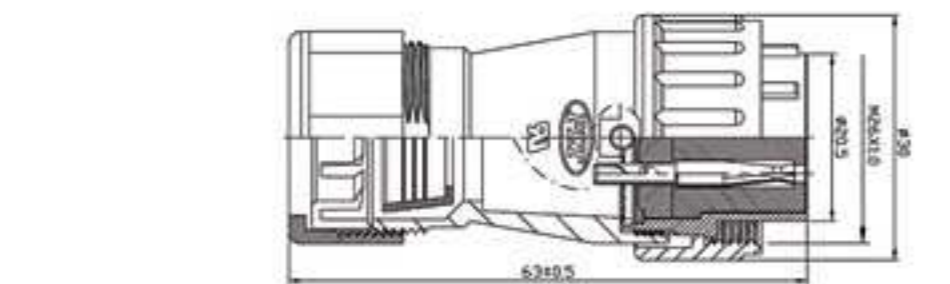
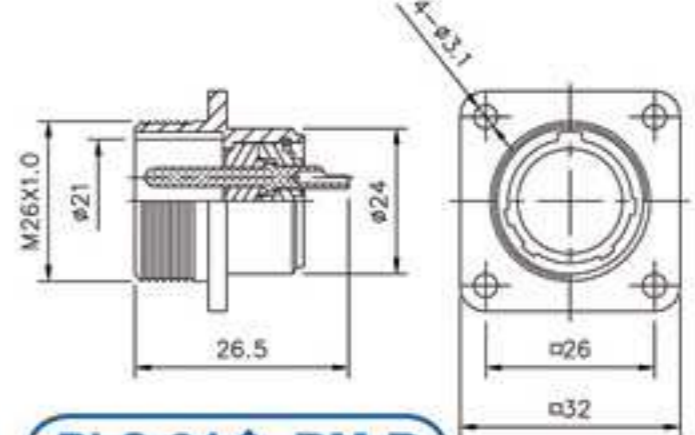

WGPF

ADM

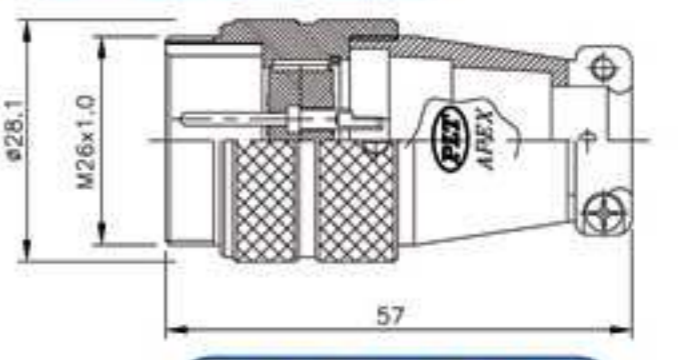

RCaC

ADGM

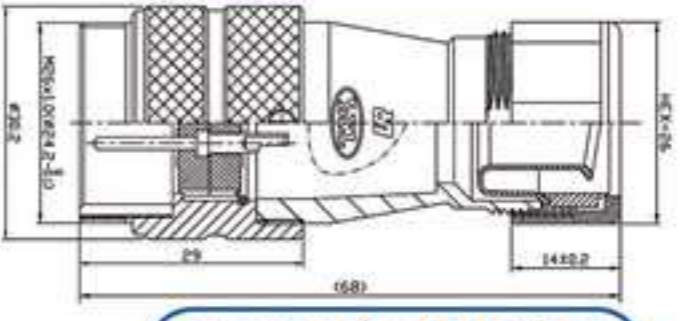

ACCESSORY:

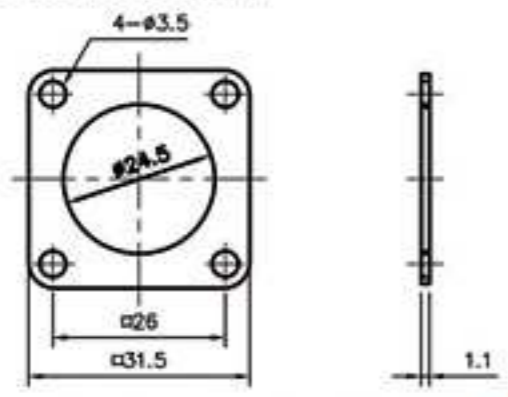

RUBBER GASKET FOR PLS-24-RM



PAT A-588PX

本件加值不加價
Value-Added with the Same Price

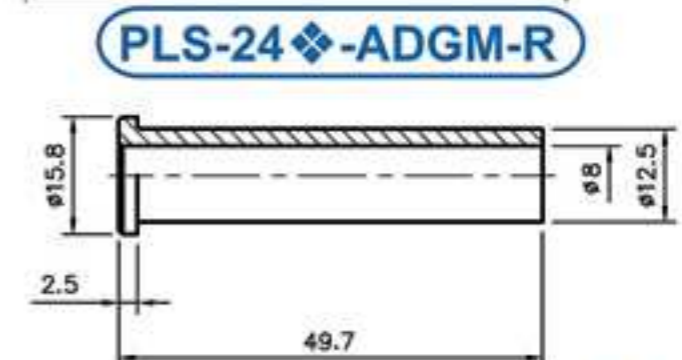

RUBBER TUBE FOR PLS-24-PF

◆ No. of contacts	5	10			
Contacts Configuration					
Rated current / voltage	15A 250V	10A 250V			
Operating voltage limit (AC.V.rms)	400	250			
Withstanding voltage (AC.V.rms) 1 minute	1800	1000			
Insulation resistance (MΩ MIN.) at DC 500V	2000	2000			
Contact resistance (mΩ MAX.) at DC 1A	3	3			
Solder inter diameter	2.8	1.6			



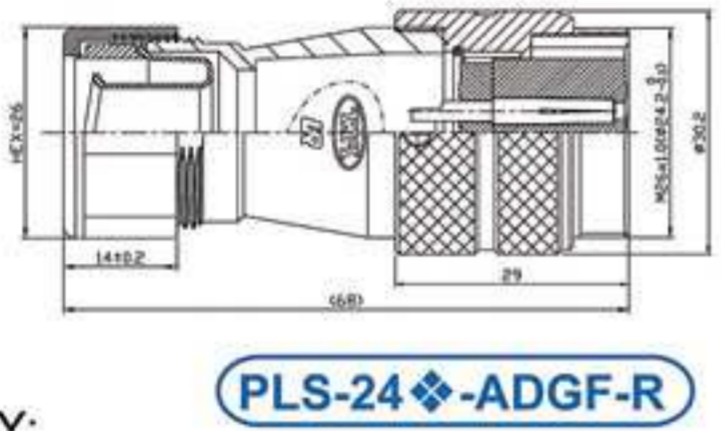
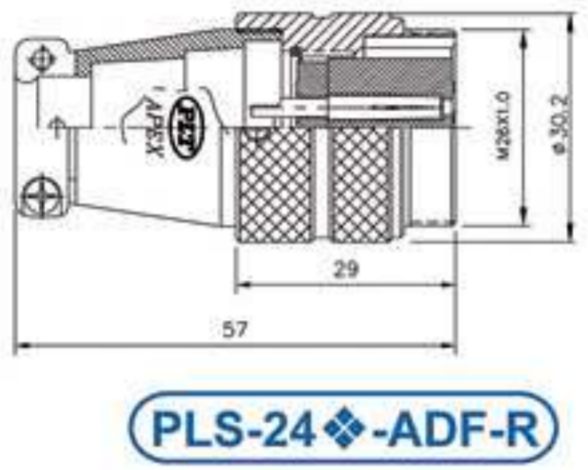
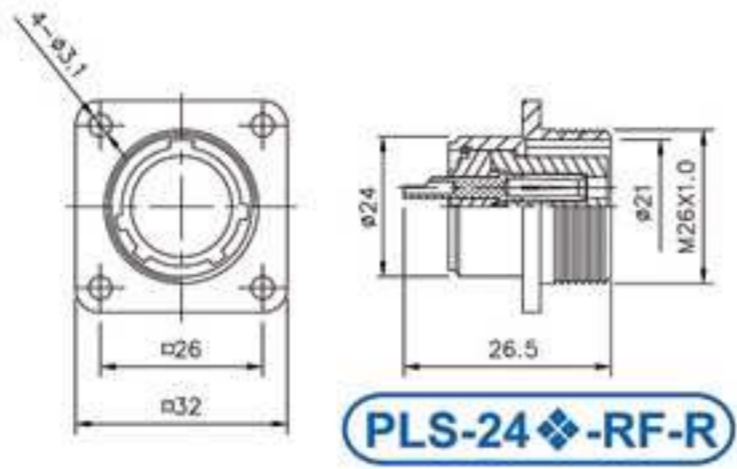

ACCESSORY:

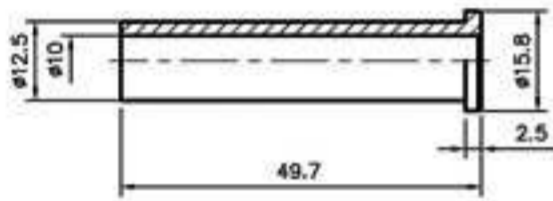

RUBBER TUBE FOR PLS-24-PM

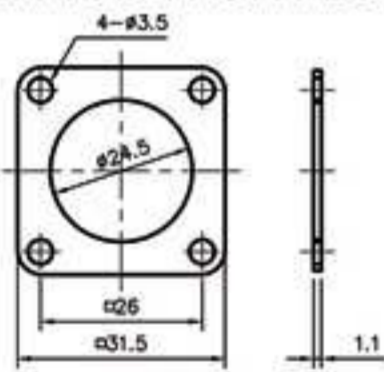

RUBBER GASKET FOR PLS-24-RF

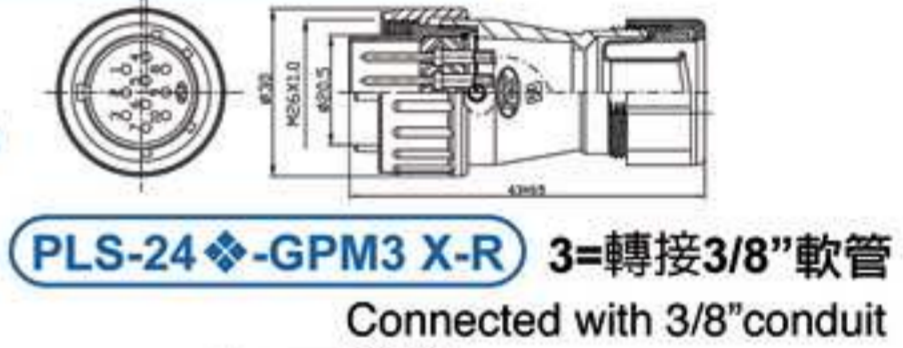
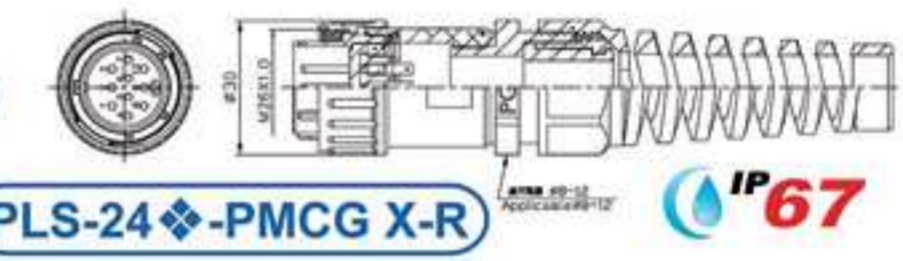
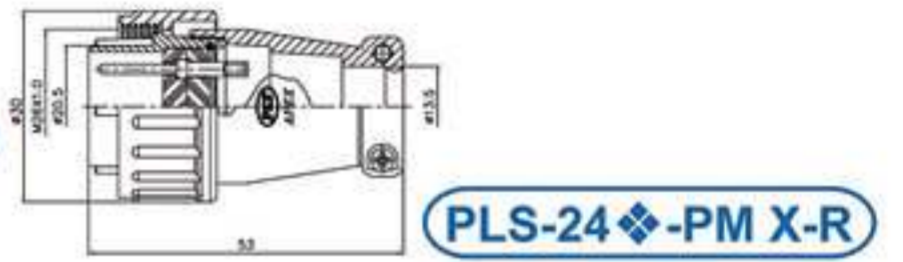
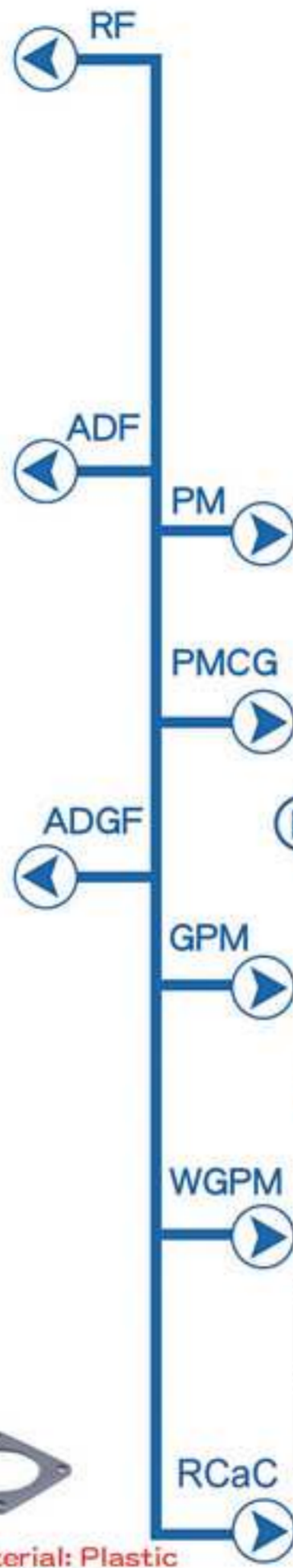

No. of contacts	5	10			
Contacts Configuration					
Rated current / voltage	15A 250V	10A 250V			
Operating voltage limit (AC.V.rms)	400	250			
Withstanding voltage (AC.V.rms) 1 minute	1800	1000			
Insulation resistance (MΩ MIN.) at DC 500V	2000	2000			
Contact resistance (mΩ MAX.) at DC 1A	3	3			
Solder inter diameter	2.8	1.6			

● 以上機種可設計防水型 Above models could be altered to waterproof types IP65 IP67 IP68





Output Type

PLS SERIES 4

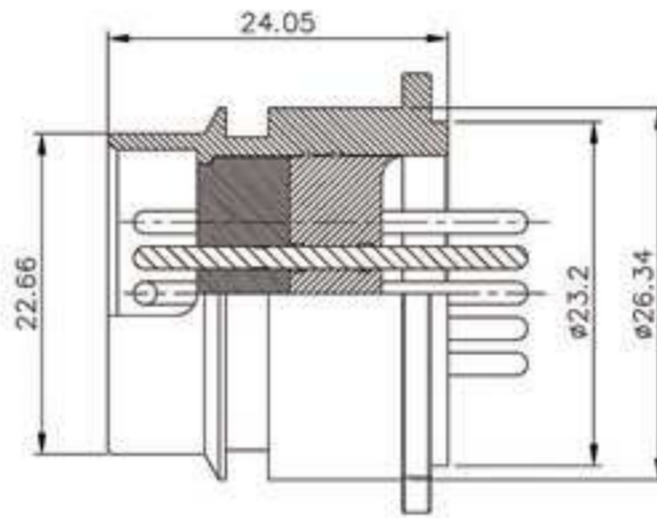
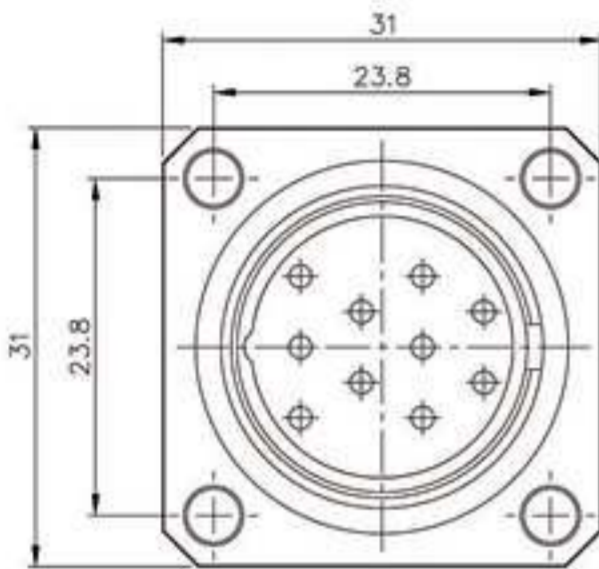

PLS-2710-RM

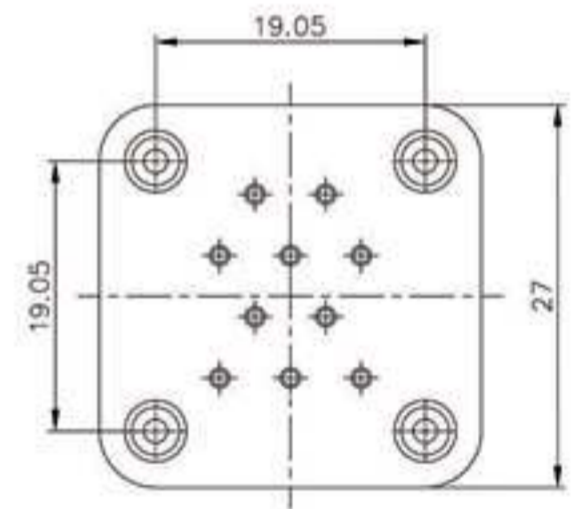
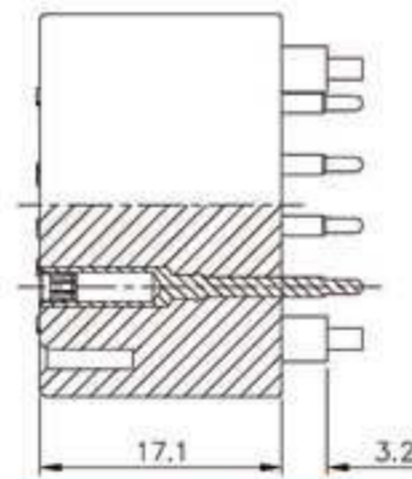
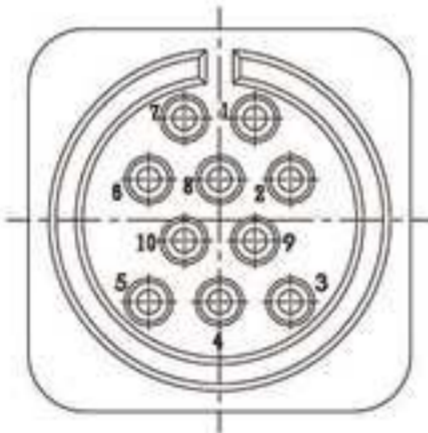

PLS-2710-PF

◆ No. of contacts	10				
Contacts Configuration					
Rated current / voltage	5A 250V				
Operating voltage limit (AC.V.rms)	250				
Withstanding voltage (AC.V.rms) 1 minute	1000				
Insulation resistance (MΩ MIN.) at DC 500V	1000				
Contact resistance (mΩ MAX.) at DC 1A	5				
Solder inter diameter					



PLS-28 Series

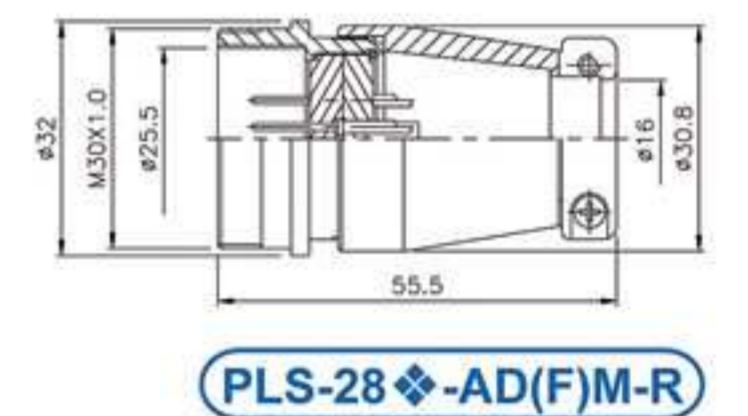
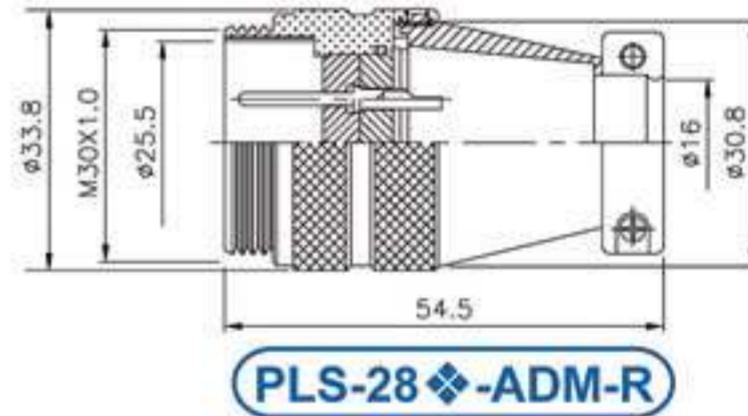
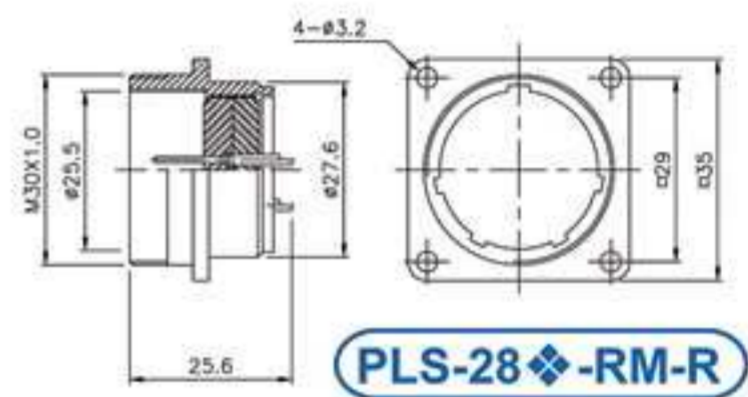
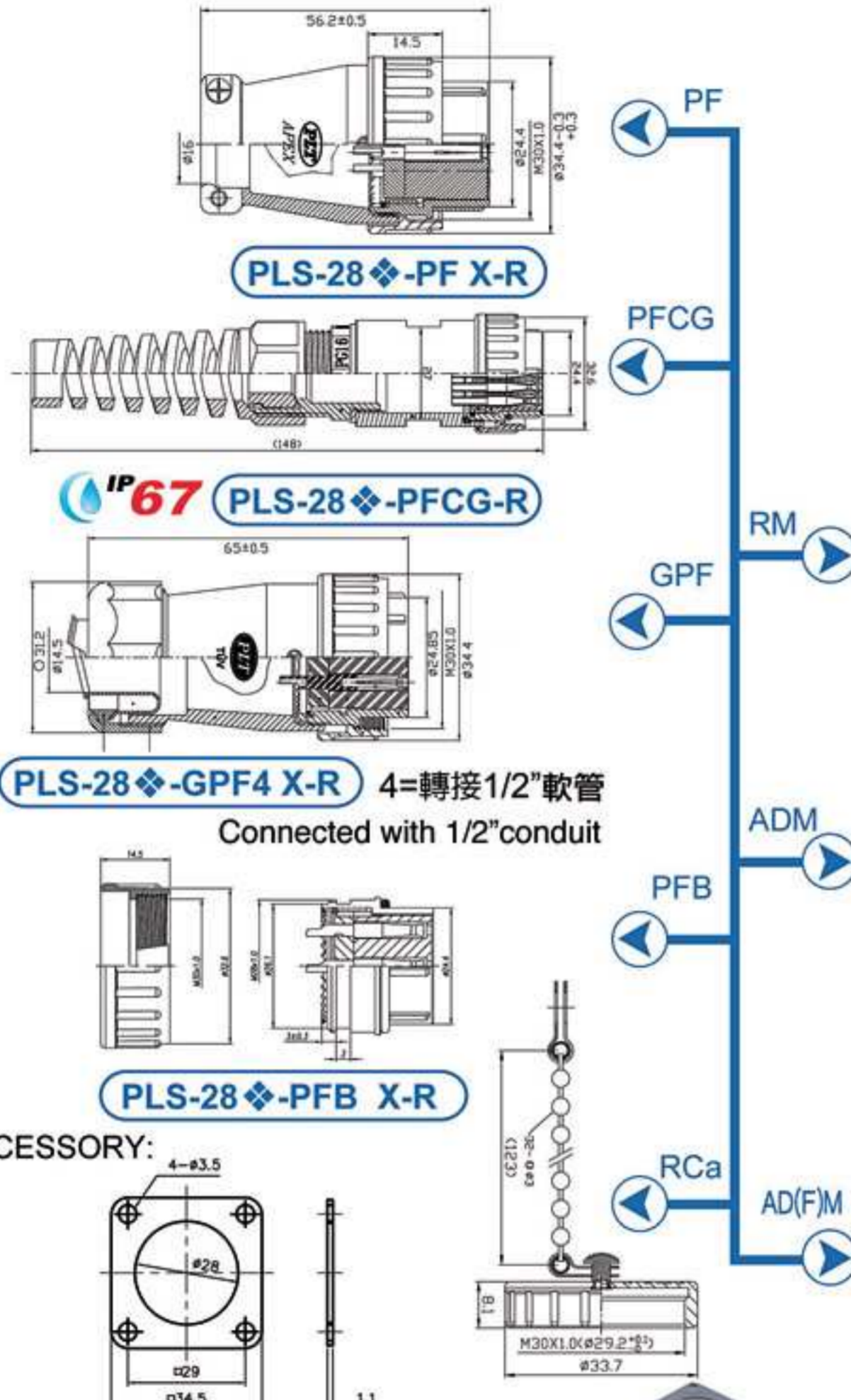

ACCESSORY:

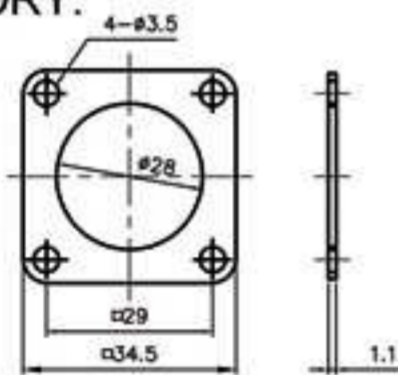

RUBBER GASKET FOR PLS-28-RM

Material: Zinc Alloy
材質: 鋅合金



PLS-28C-RCa-R



Material: Plastic
材質: 塑膠

PAT A-589PX (Option)

本件加值不加價
Value-Added with the Same Price

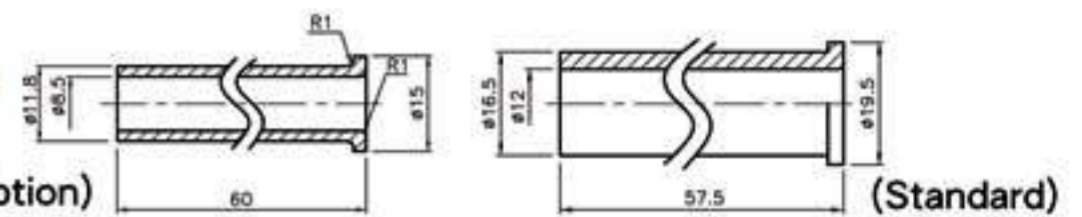

RUBBER TUBE FOR PLS-28-PF

No. of contacts	3	4	7	12	16	17	20	26
Contacts Configuration								
Rated current / voltage	15A 250V	15A 250V	15A 250V	10A 250V	10A 250V	10A 250V	5A 250V	5A 250V
Operating voltage limit (AC.V.rms)	400	400	400	250	250	250	250	250
Withstanding voltage (AC.V.rms) 1 minute	2000	2000	1800	1000	1000	1000	1000	1000
Insulation resistance (MΩ MIN.) at DC 500V	2000	2000	2000	1000	1000	1000	1000	1000
Contact resistance (mΩ MAX.) at DC 1A	3	3	3	5	5	5	3	3
Solder inter diameter	3.4	3.4	2.4	1.6	1.6	1.6	1.2	1.2

Output Type



PLS SERIES 4

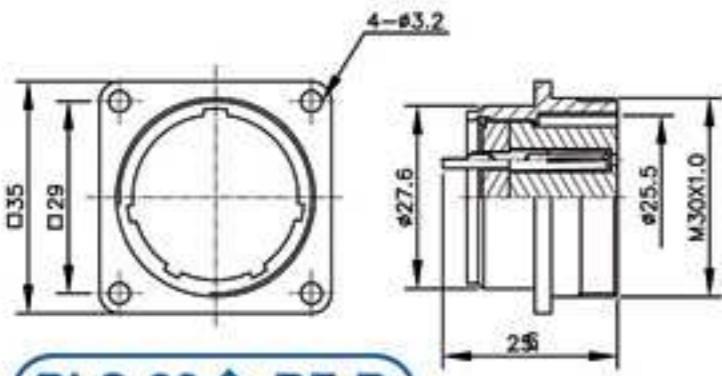

PLS-28-RF-R

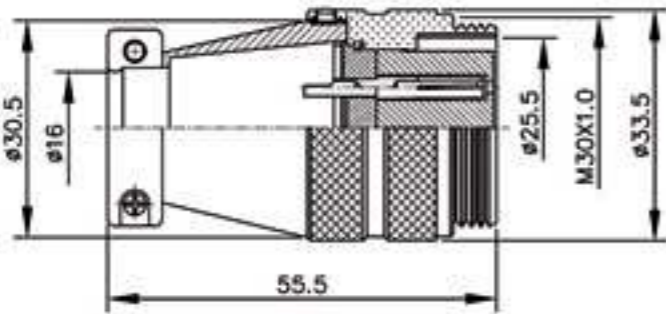

PLS-28-ADF-R



PLS-2812E-RF-R

ACCESSORY:

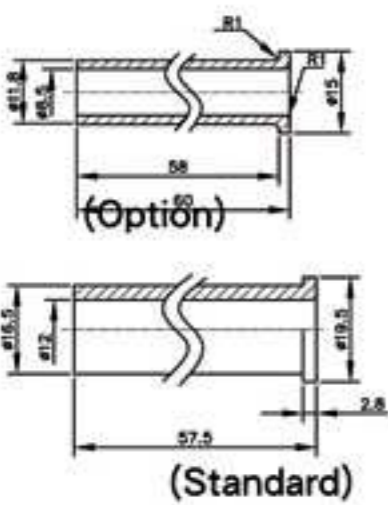

(Standard)



RUBBER GASKET FOR PLS-28-RF

RUBBER TUBE FOR PLS-28-PM



IP67 PLS-28-PMCG-R



PLS-28-PM X-R

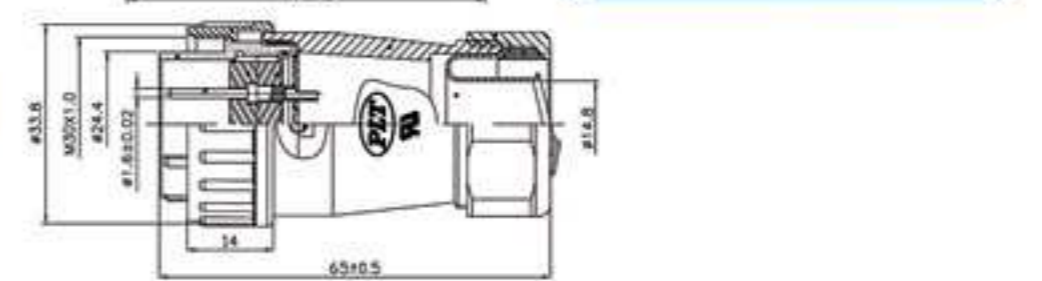

PLS-28-GPM4 X-R 4=轉接1/2"軟管
Connected with 1/2"conduit



PLS-28-PMA XB-R

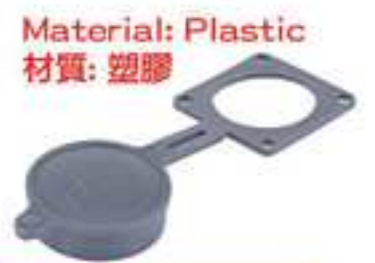

PAT A-589PX

本件加值不加價
Value-Added with the Same Price



PLS-28C-RCa-R

Material: Zinc Alloy
材質: 鋅合金

◆ No. of contacts	3	4	7	12	16	17	20	26
Contacts Configuration								
Rated current / voltage	15A 250V	15A 250V	15A 250V	10A 250V	10A 250V	10A 250V	5A 250V	5A 250V
Operating voltage limit (AC.V.rms)	400	400	400	250	250	250	250	250
Withstanding voltage (AC.V.rms) 1 minute	2000	2000	1800	1000	1000	1000	1000	1000
Insulation resistance (MΩ MIN.) at DC 500V	2000	2000	2000	1000	1000	1000	1000	1000
Contact resistance (mΩ MAX.) at DC 1A	3	3	3	5	5	5	3	3
Solder inter diameter	3.4	3.4	2.4	1.6	1.6	1.6	1.2	1.2



4
PLS SERIES

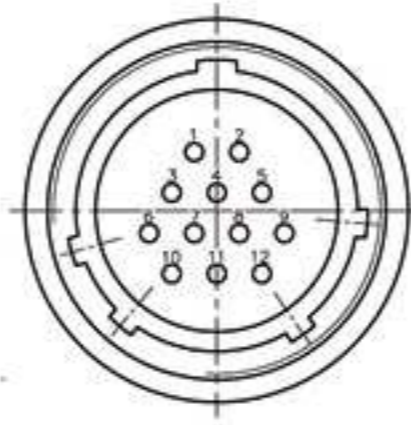
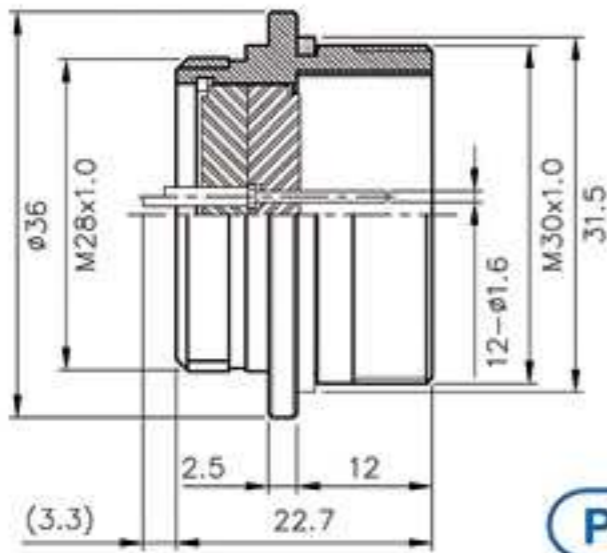

PLS-28-RMA-R

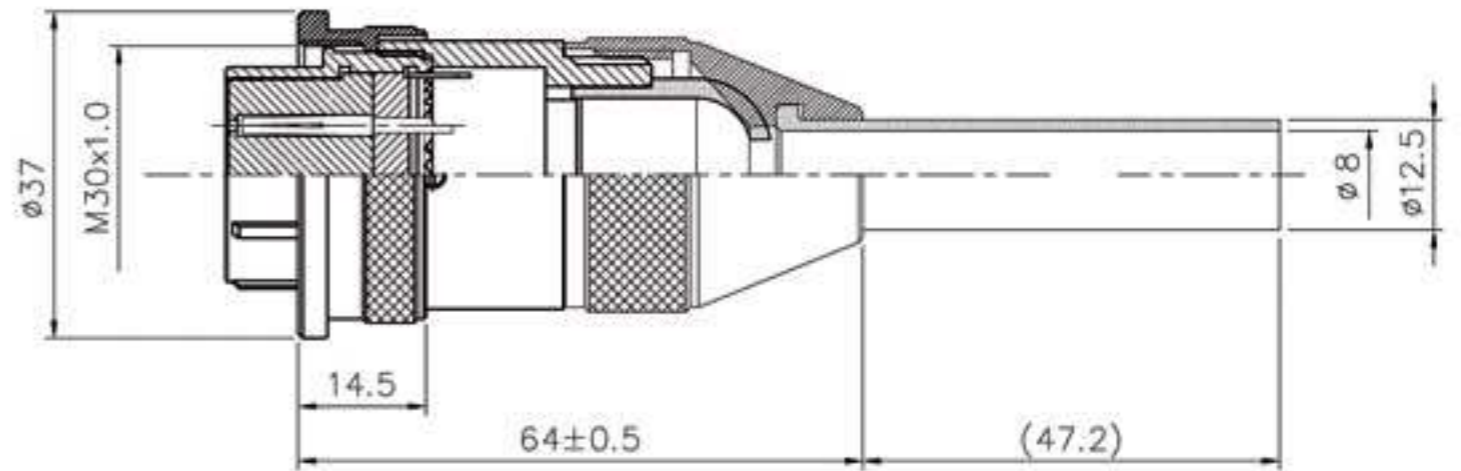

PLS-28-PFA-R

(Stainless Steel 不鏽鋼)

No. of contacts	3	4	7	12	16	17	20	26
Contacts Configuration								
Rated current / voltage	15A 250V	15A 250V	15A 250V	10A 250V	10A 250V	10A 250V	5A 250V	5A 250V
Operating voltage limit (AC.V.rms)	400	400	400	250	250	250	250	250
Withstanding voltage (AC.V.rms) 1 minute	2000	2000	1800	1000	1000	1000	1000	1000
Insulation resistance (MΩ MIN.) at DC 500V	2000	2000	2000	1000	1000	1000	1000	1000
Contact resistance (mΩ MAX.) at DC 1A	3	3	3	5	5	5	3	3
Solder inter diameter	3.4	3.4	2.4	1.6	1.6	1.6	1.2	1.2





Input Type

PLS SERIES 4

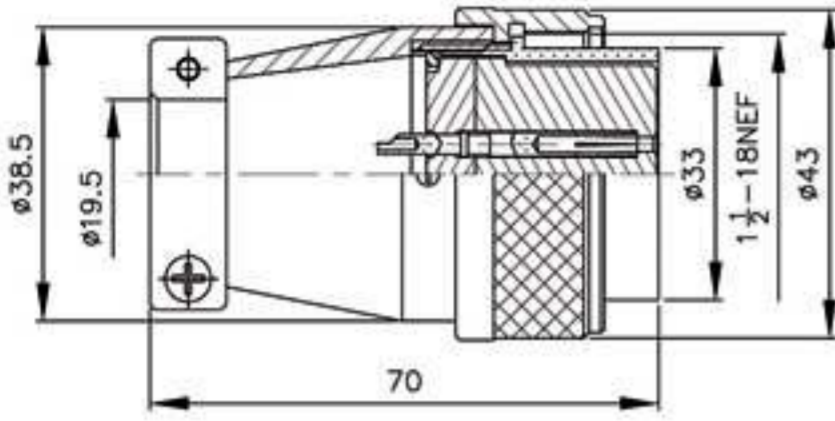

PLS-35-PF-R

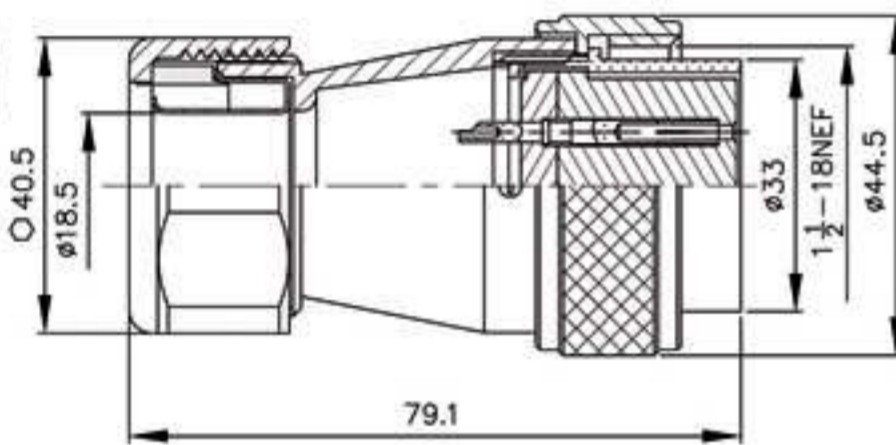

PLS-35-GPF6-R 6=轉接3/4"軟管
Connected with 3/4" conduit

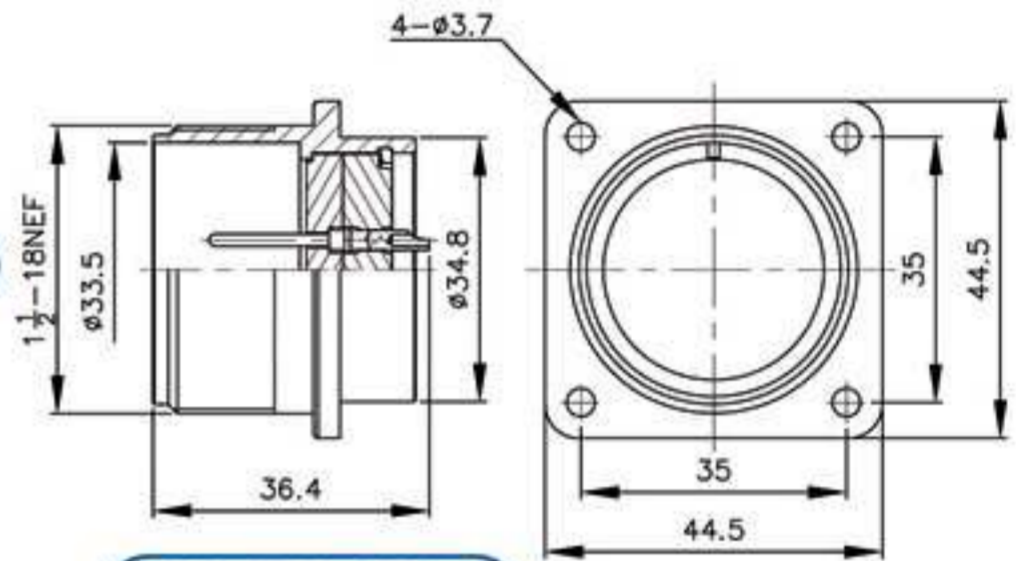
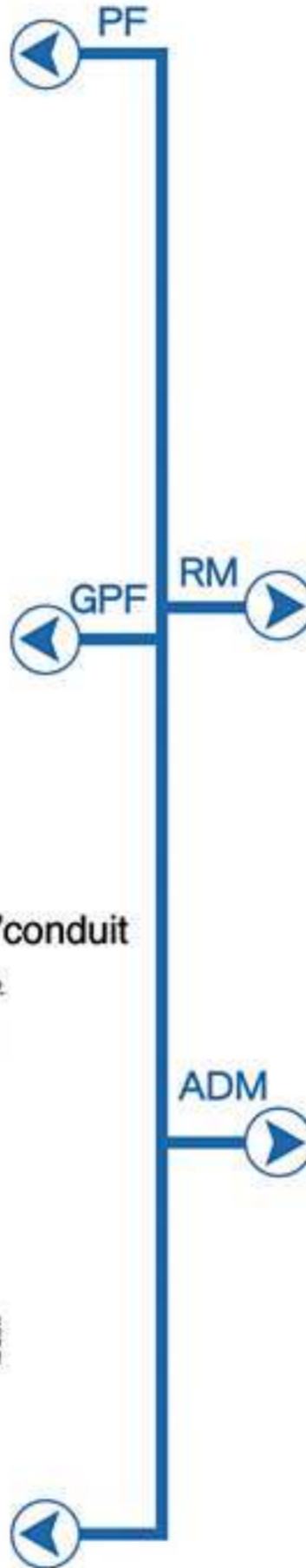

PLS-35-RM-R

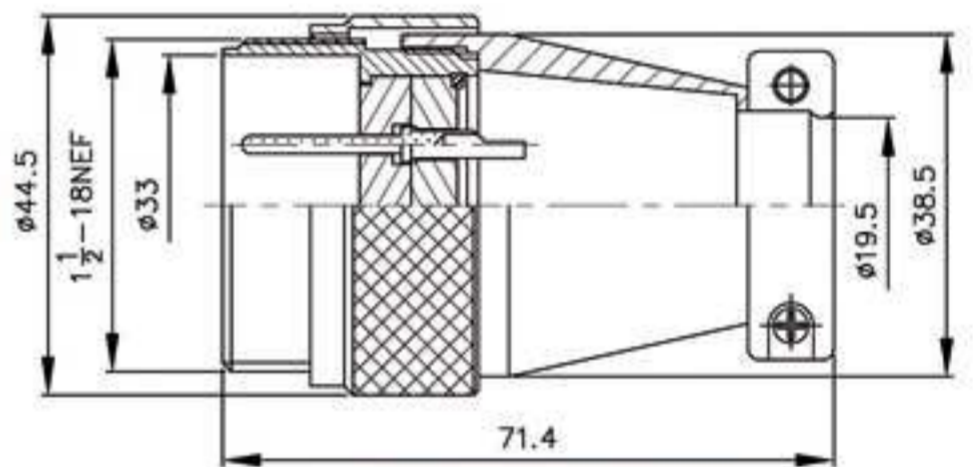

PLS-35-ADM-R

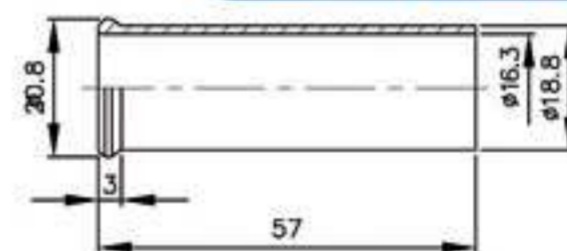

RUBBER TUBE :
ACCESSORY FOR PLS-35-P

Material: Aluminum Alloy
材質: 鋁合金



AMS25043-24A

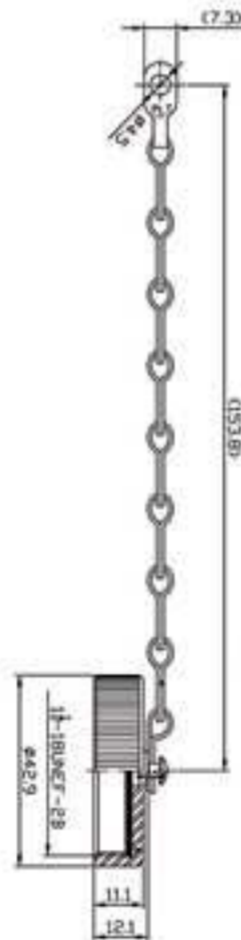

No. of contacts	24						
Contacts Configuration	 TUV						
Rated current / voltage	8A 250V						
Operating voltage limit (AC.V.rms)	200						
Withstanding voltage (AC.V.rms) 1 minute	1000						
Insulation resistance (MΩ MIN.) at DC 500V	1000						
Contact resistance (mΩ MAX.) at DC 1A	3						
Solder inter diameter	1.8						



4

PLS SERIES

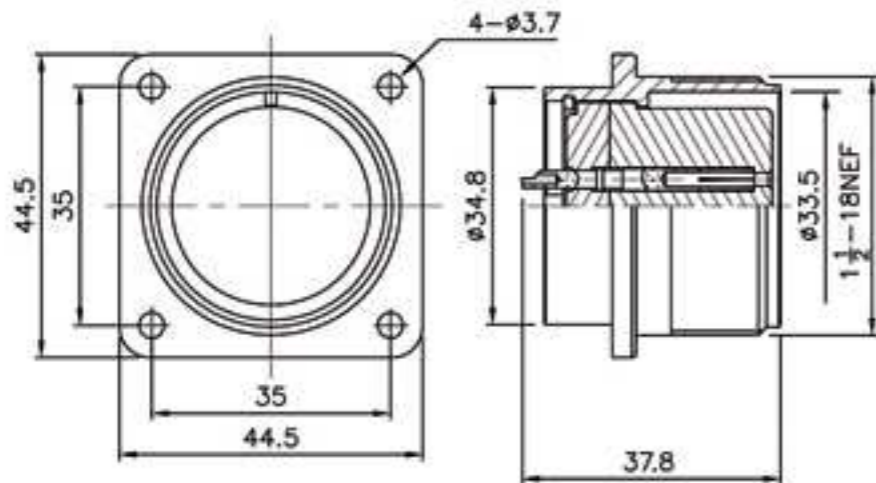

PLS-35-RF-R

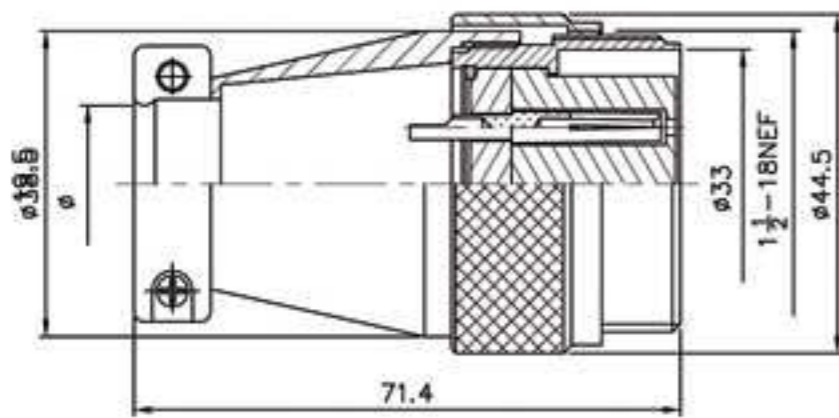

PLS-35-ADF-R

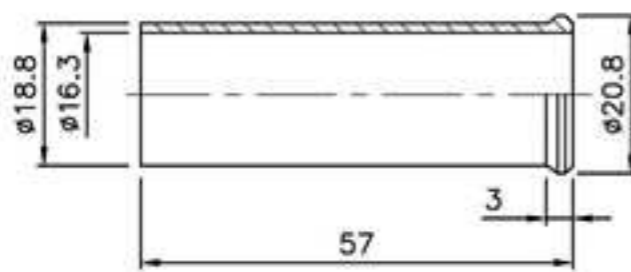

RUBBER TUBE :
ACCESSORY FOR PLS-35-PM

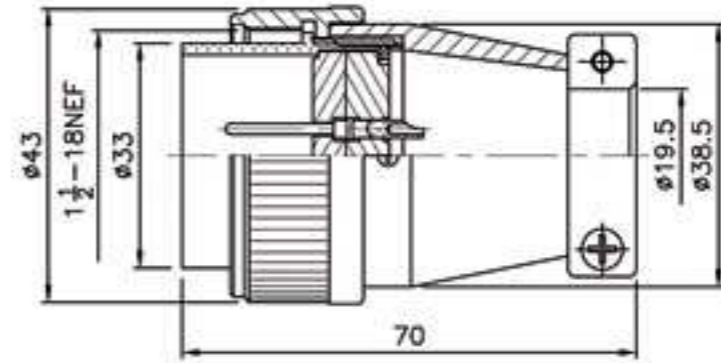

PLS-35-PM-R

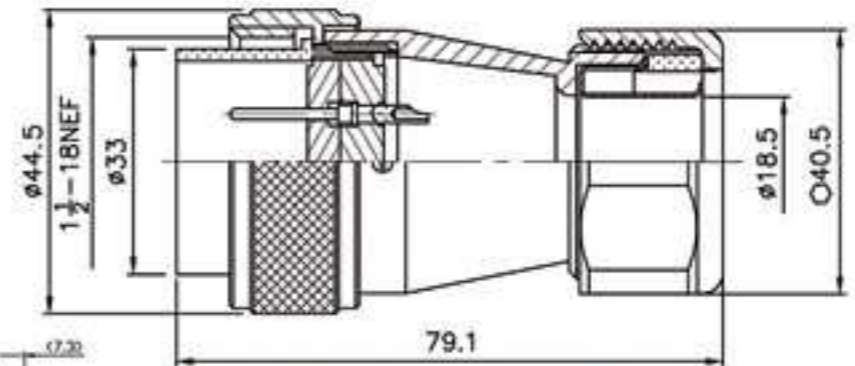

PLS-35-GPM6-R

6=轉接3/4"軟管
Connected with 3/4"conduit

Material: Aluminum Alloy
材質: 鋁合金



AMS25043-24A

◆ No. of contacts	24				
Contacts Configuration	 TUV				
Rated current / voltage	8A 250V				
Operating voltage limit (AC.V.rms)	200				
Withstanding voltage (AC.V.rms) 1 minute	1000				
Insulation resistance (MΩ MIN.) at DC 500V	1000				
Contact resistance (mΩ MAX.) at DC 1A	3				
Solder inter diameter	1.8				



Input Type / Output Type

PLS SERIES 4

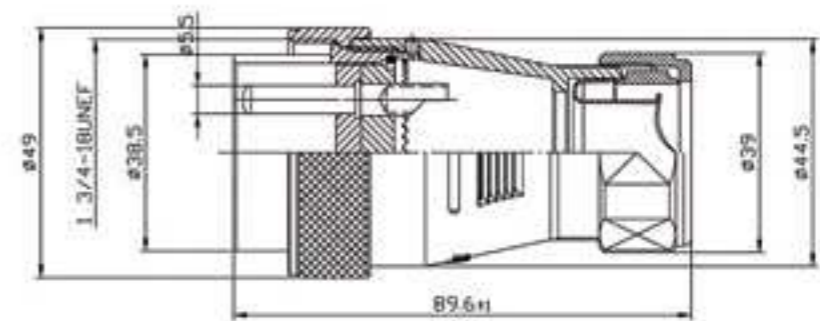
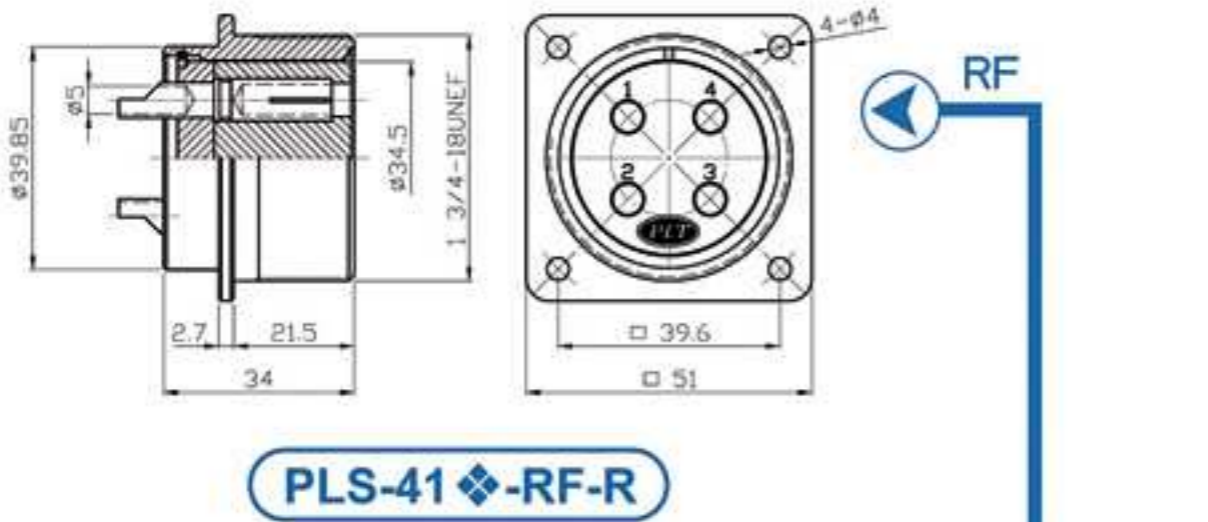

PLS-41-GPM6-R

6=轉接3/4"軟管
Connected with 3/4"conduit

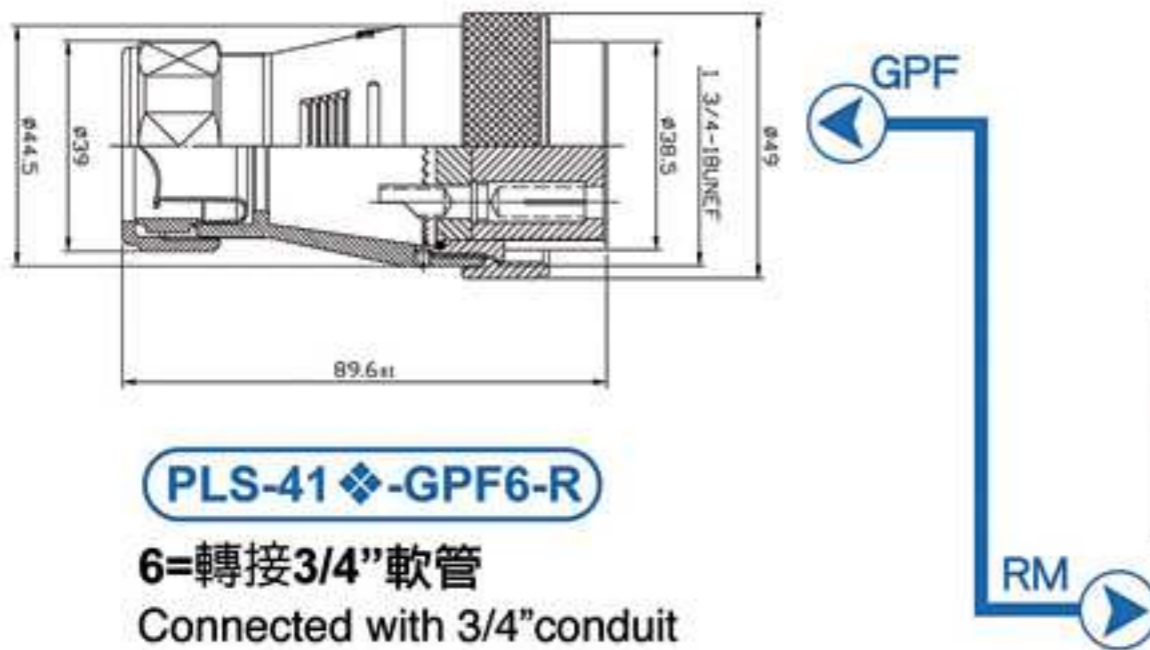

6=轉接3/4"軟管
Connected with 3/4"conduit

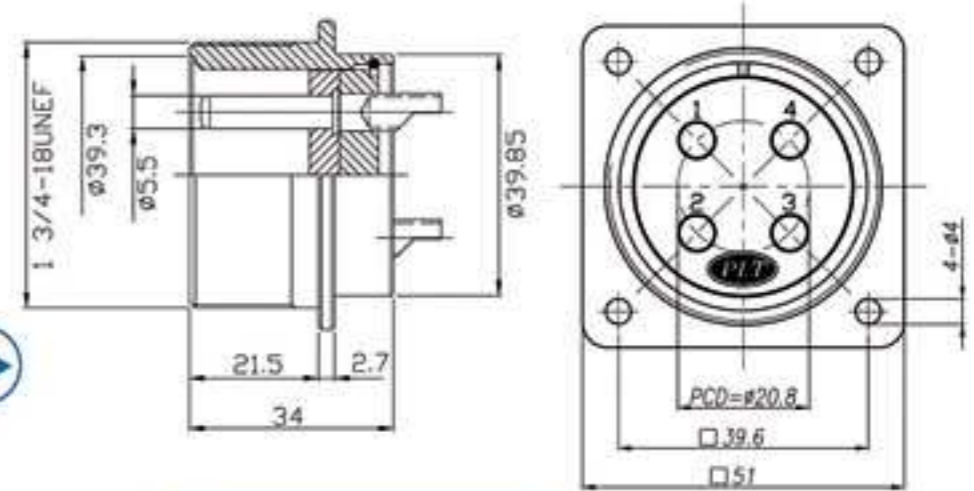

◆ No. of contacts	4	8				
Contacts Configuration						
Rated current / voltage	30A 250V	15A 250V				
Operating voltage limit (AC.V.rms)	500	400				
Withstanding voltage (AC.V.rms) 1 minute	2500	2000				
Insulation resistance (MΩ MIN.) at DC 500V	2500	2000				
Contact resistance (mΩ MAX.) at DC 1A	3	3				
Solder inter diameter	5	3.5				



PLS-42 Series

4

PLS SERIES

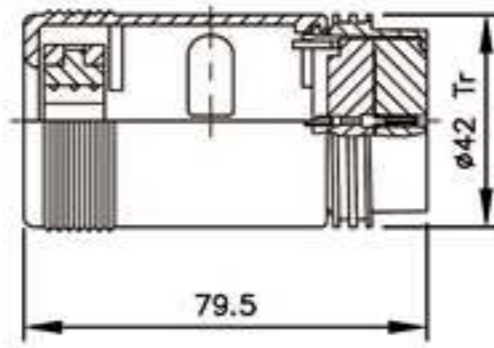
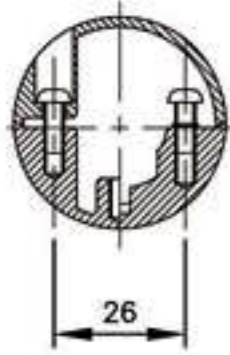

PLS-42 ◆-PF

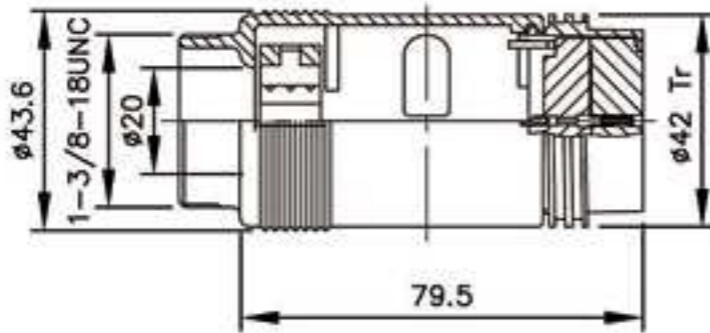
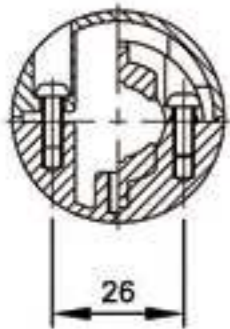

PLS-42 ◆-PF1

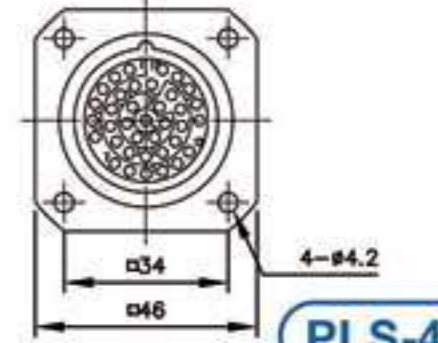
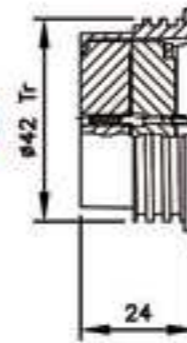

PLS-42 ◆-RF

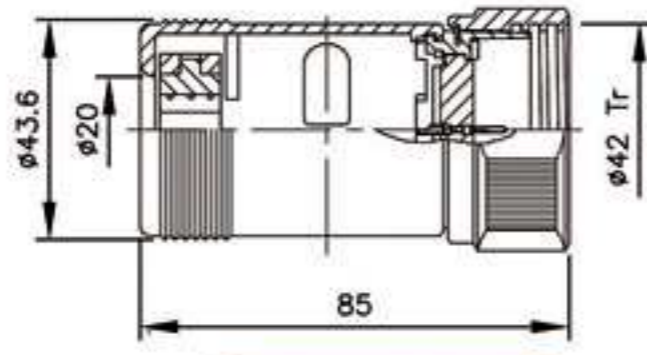
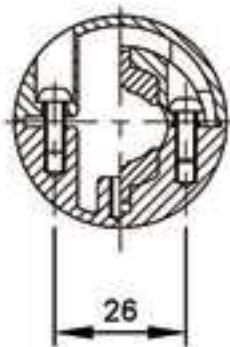

PLS-42 ◆-PM

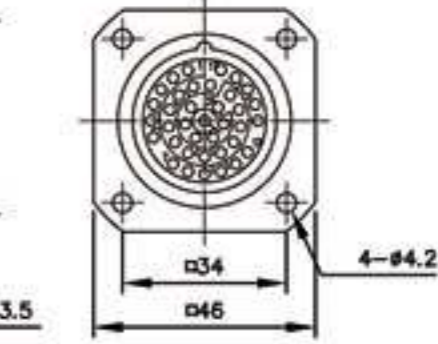
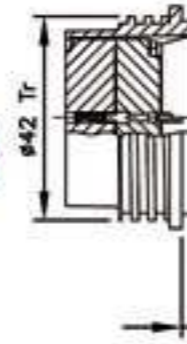

PLS-42 ◆-RF1

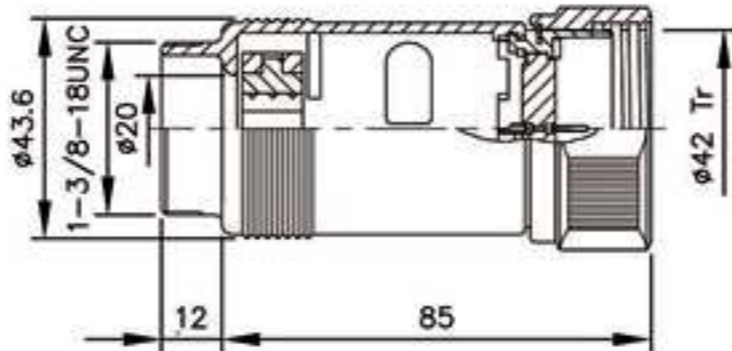
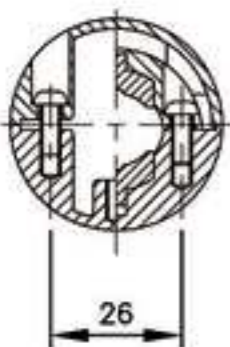

PLS-42 ◆-PM1

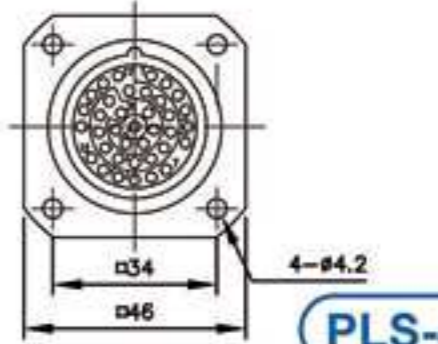
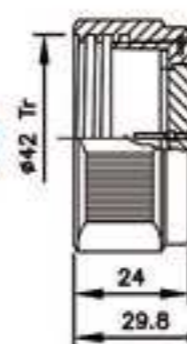

PLS-42 ◆-RM

Accessory:
Cable Clamp

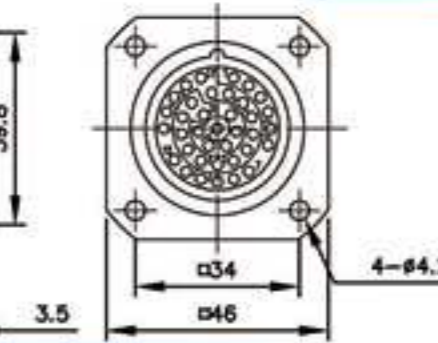
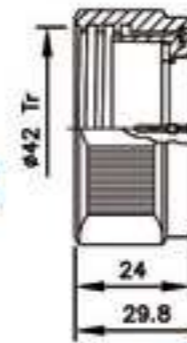
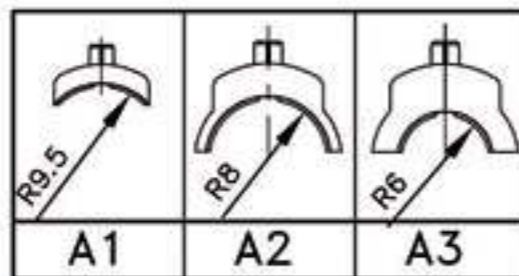

PLS-42 ◆-RM1



◆ No. of contacts	7	37			
Contacts Configuration					
Rated current / voltage	13A 250V	5A 250V			
Operating voltage limit (AC.V.rms)	500	500			
Withstanding voltage (AC.V.rms) 1 minute	2000	3000			
Insulation resistance (MΩ MIN.) at DC 500V	2000	2000			
Contact resistance (mΩ MAX.) at DC 1A	3	3			
Solder inter diameter	3.5	1.2			



PLP Series



PLP Series



PLP Series



PLP Series



PLP-141P20 Series



PLP-154P6 Series



M-6029 Series



PLTS-40 Series

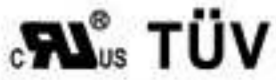

Input Type/Output Type



PLP-124B-24B-PM
 PLP-124B-24B-PF
 PLP-124C-24B-PM
 PLP-124C-24B-PF



PLP-116A-PM



PLP-124A-PM



PLP-116A-RF



PLP-124A-RF



PLP Series

PLP-124B-24B+
 PLP-124B-24C



PLP-124B-24B-PF+
 PLP-124HI-24C-RM



PLP-124B-24B-PF+
 PLP-124A-RM



PLP-124A-24F+
 PLP-124A-24M

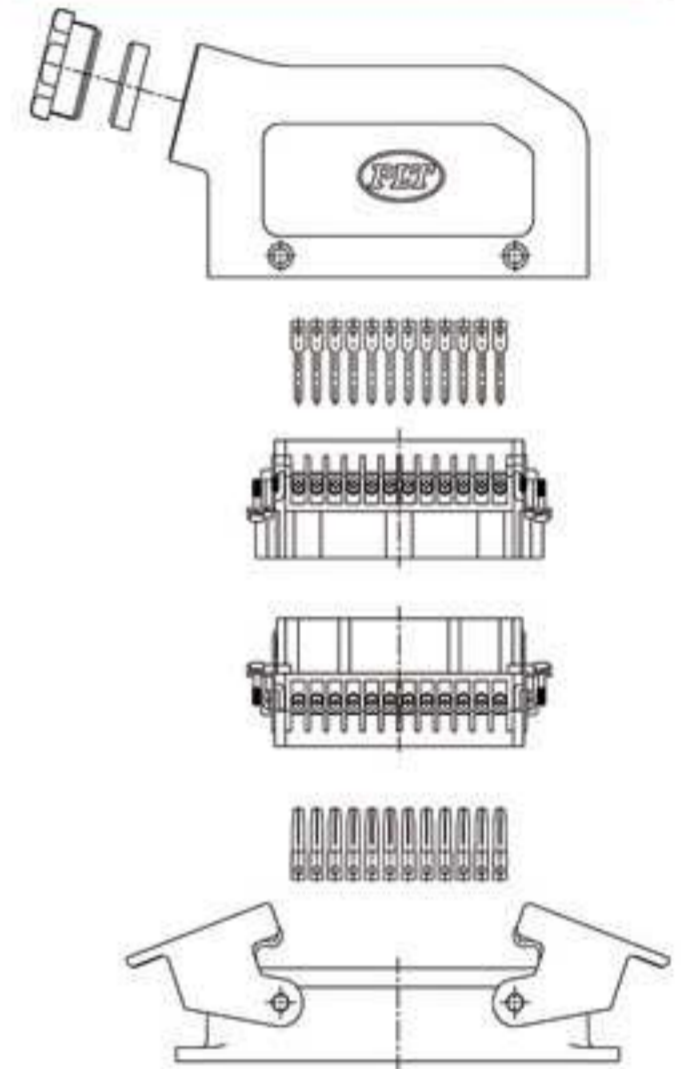

MALE INSERT
 PLP-116A-16M



MALE

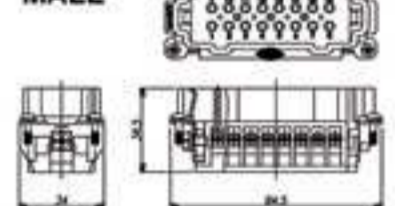

FEMALE INSERT
 PLP-116A-16F



FEMALE

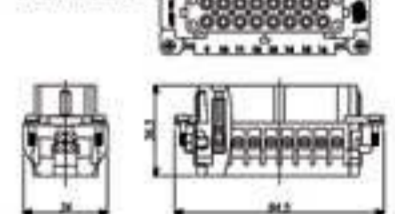

HOODS
 PLP-116A-16B

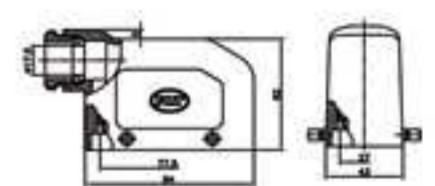

HOUSING
 PLP-116A-16C

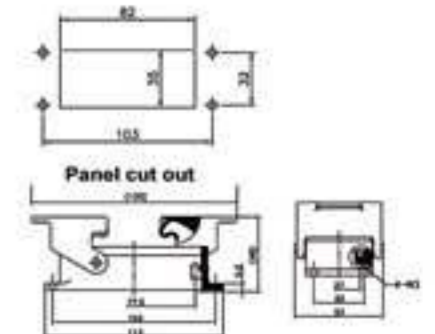

ORDERING INFORMATION

PLP-116A - 16B

- 16B : 16 POLE HOOD
- 16C : 16 POLE HOUSING
- 24B : 24 POLE HOOD
- 24C : 24 POLE HOUSING
- NUMBER OF CONTACTS
- SERIES
- 16M : 16 POLE MALE INSERT
- 16F : 16F POLE FEMALE INSERT
- 24M : 24 POLE MALE INSERT
- 24F : 24 POLE FEMALE INSERT

- Rated Current : 16A max
- Rated Voltage : 380 ~ 450V
- Withstand Voltage (AC. V. r.m.s) 1 Minute : 3000V
- Contact Resistance (mΩ Max) at DC 1A : 1 mΩ
- Insulation Resistance : 5000 mΩ
- Water Protection : IP65
- Temperature Range : -40 °C ~ 125 °C

● 以上機種可設計防水型 Above models could be altered to waterproof types IP65 IP67 IP68





PLP-141P20 Series

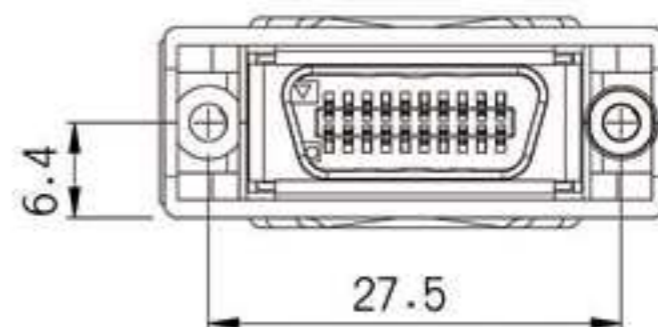
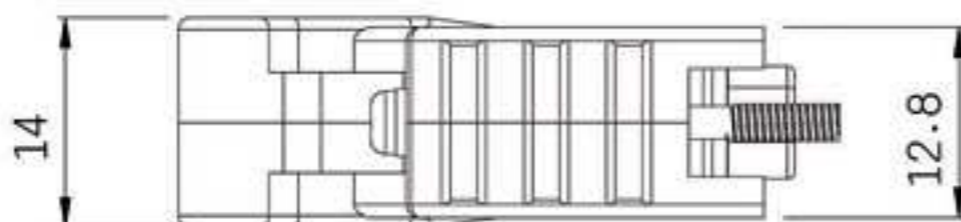
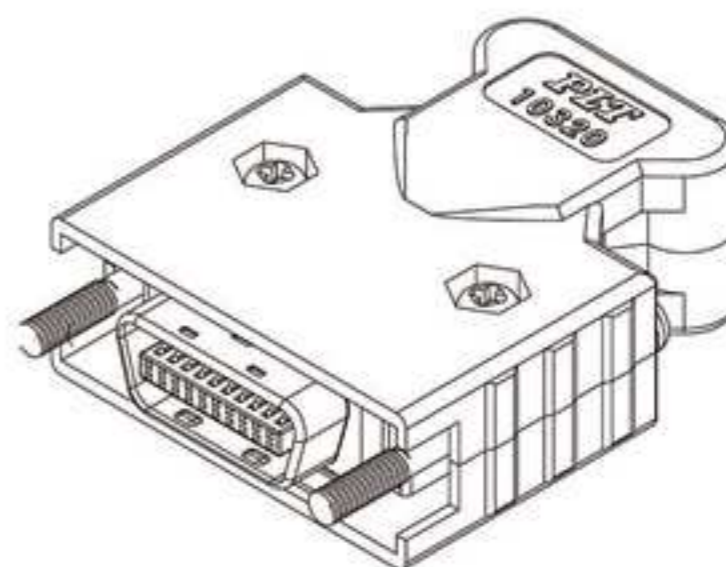
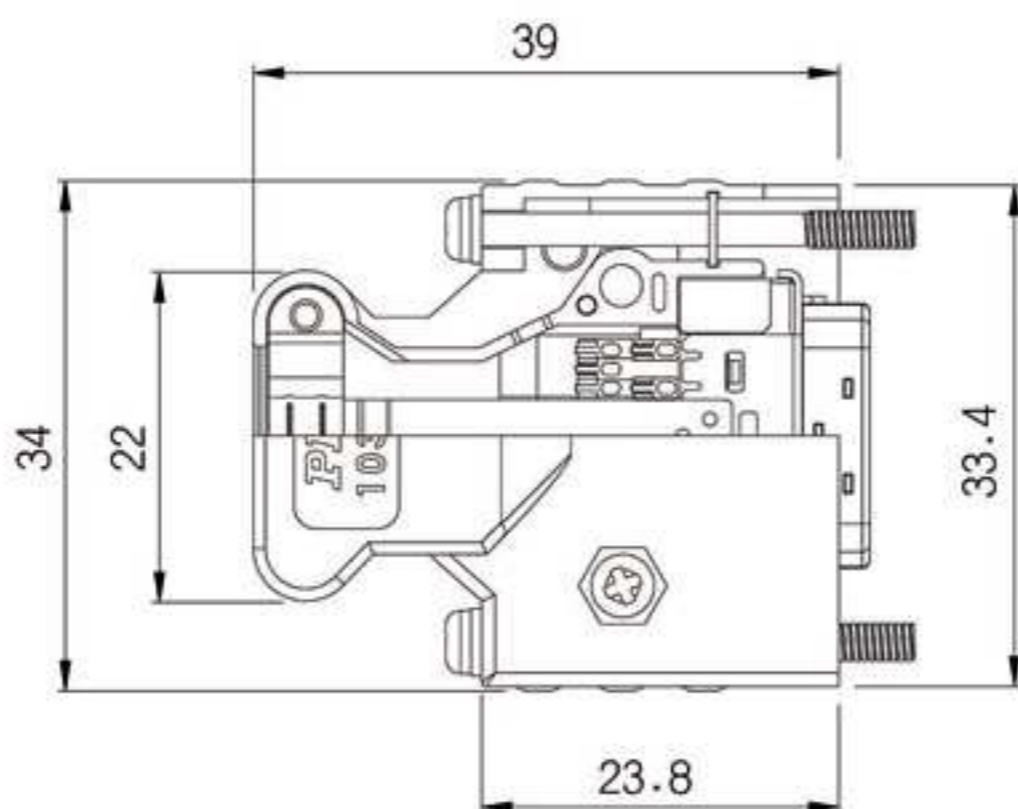

◆ No. of contacts	20				
Contacts Configuration					
Rated current	1A				
Withstanding voltage (AC.V.rms) 1 minute	500				
Insulation resistance (MΩ MIN.) at DC 500V	>1 X 10 ⁸ Ω				

PLP Series



5
PLP SERIES

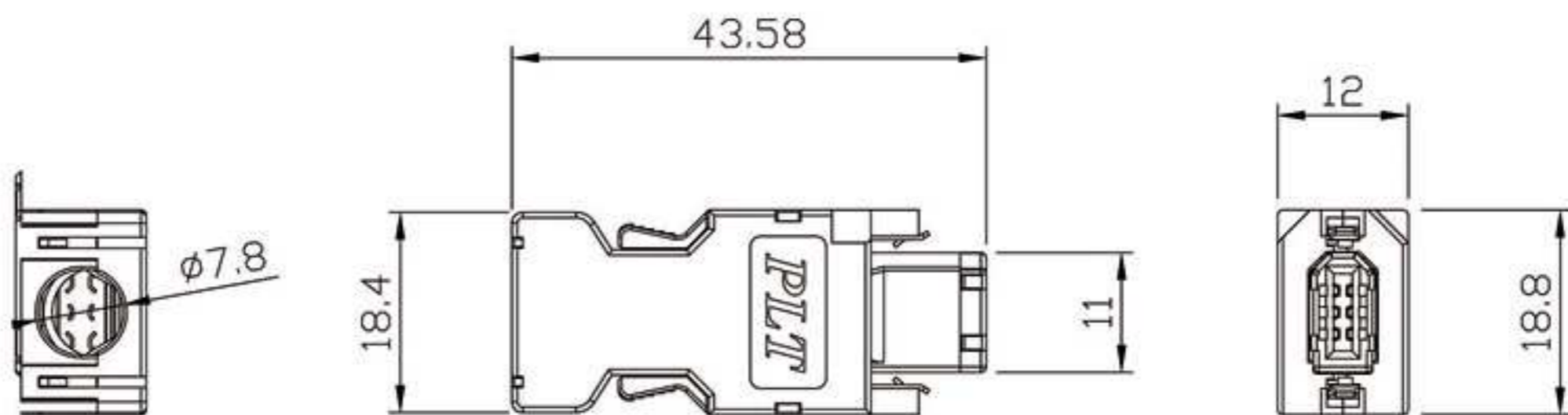
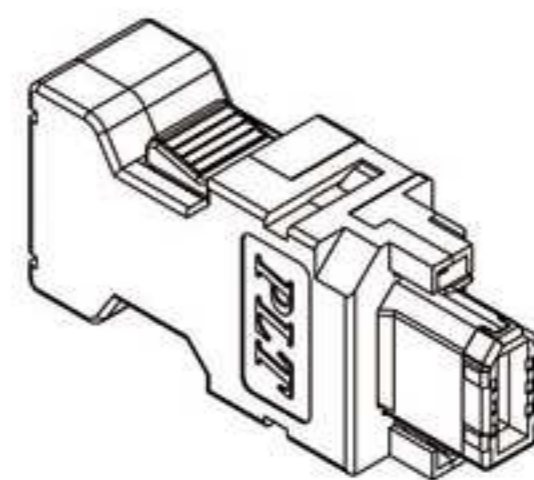
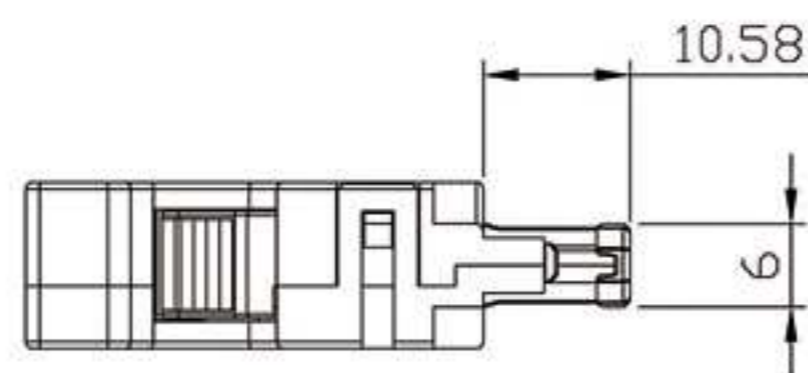

◆ No. of contacts	6					
Contacts Configuration						
Rated current / voltage						
Operating voltage limit (AC.V.rms)						
Withstanding voltage (AC.V.rms) 1 minute	350					
Insulation resistance (MΩ MIN.) at DC 500V	1000					
Contact resistance (mΩ MAX.) at DC 1A	20					

● 以上機種可設計防水型 Above models could be altered to waterproof types

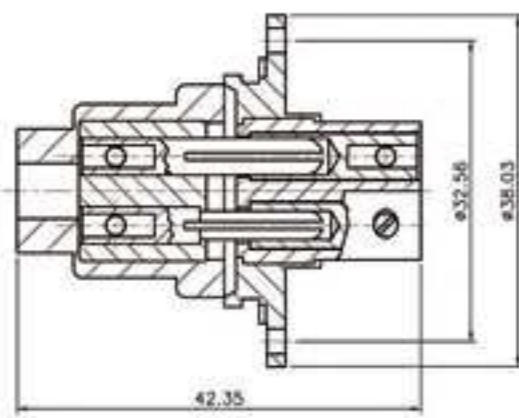

M-6029

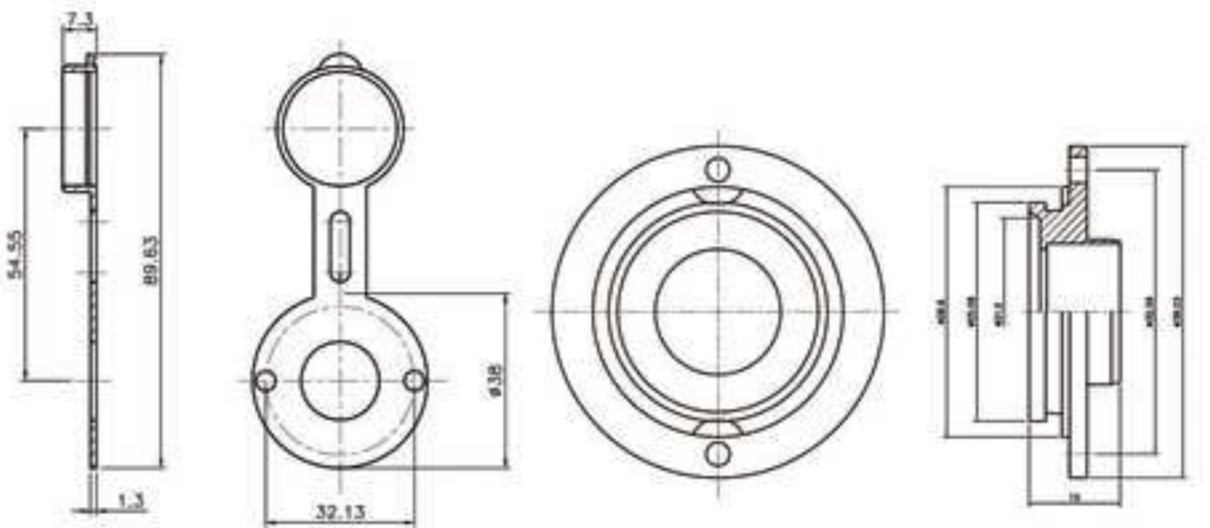

M-6029



Multi-Jointed Connectors for Machine Plate

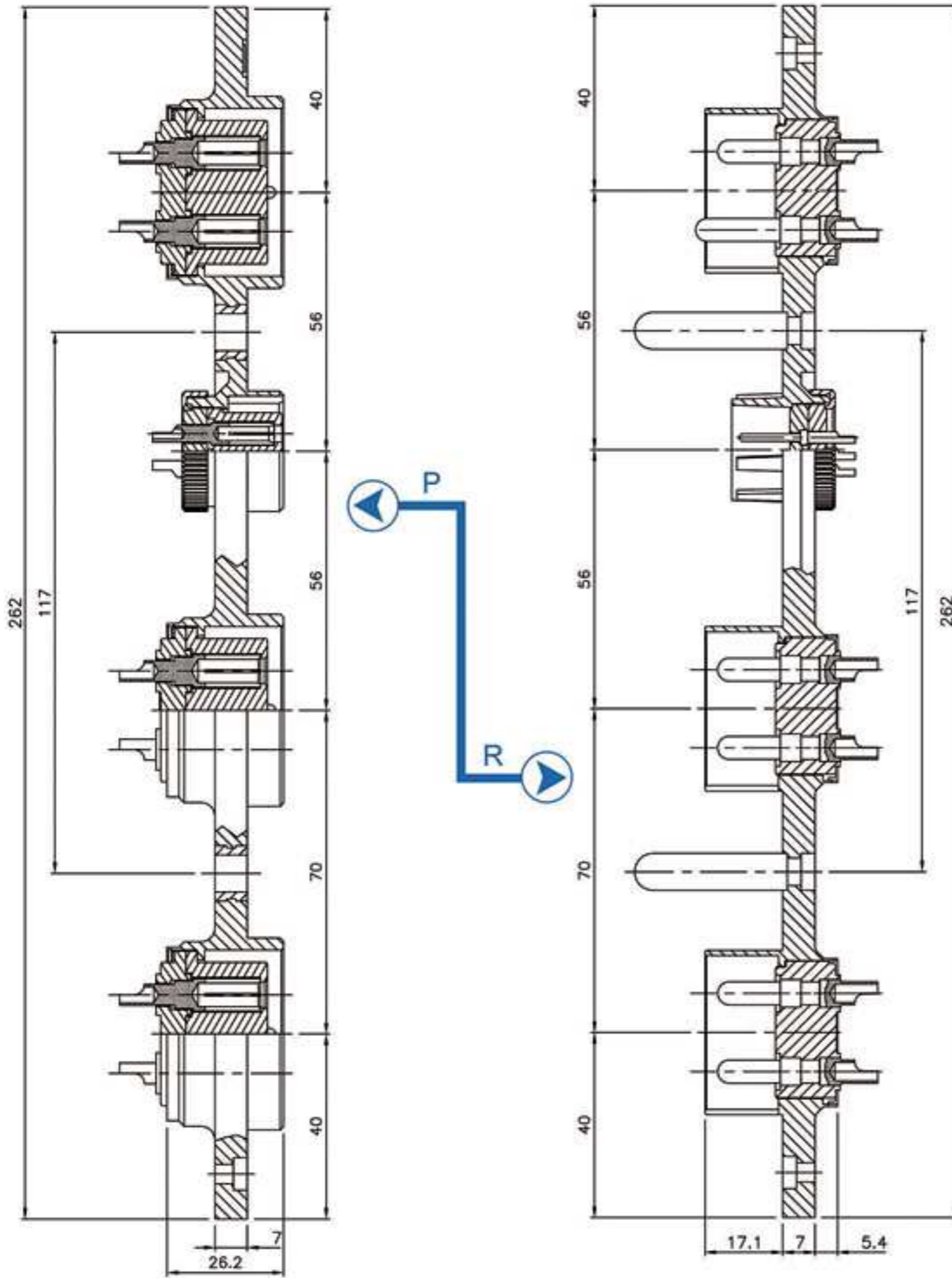

PLTS-40 Series

PAT PLTS-40◆-P

PAT PLTS-40◆-R

◆ No. of contacts	4				
Contacts Configuration					
Rated current / voltage	30A 250V				
Operating voltage limit (AC.V.rms)	500				
Withstanding voltage (AC.V.rms) 1 minute	2500				
Insulation resistance (MΩ MIN.) at DC 500V	2000				
Contact resistance (mΩ MAX.) at DC 1A	3				
Solder inter diameter	4				

Multi-Jointed Connectors for Machine Plate



COMPLEX SERIES - PLTS SERIES 5

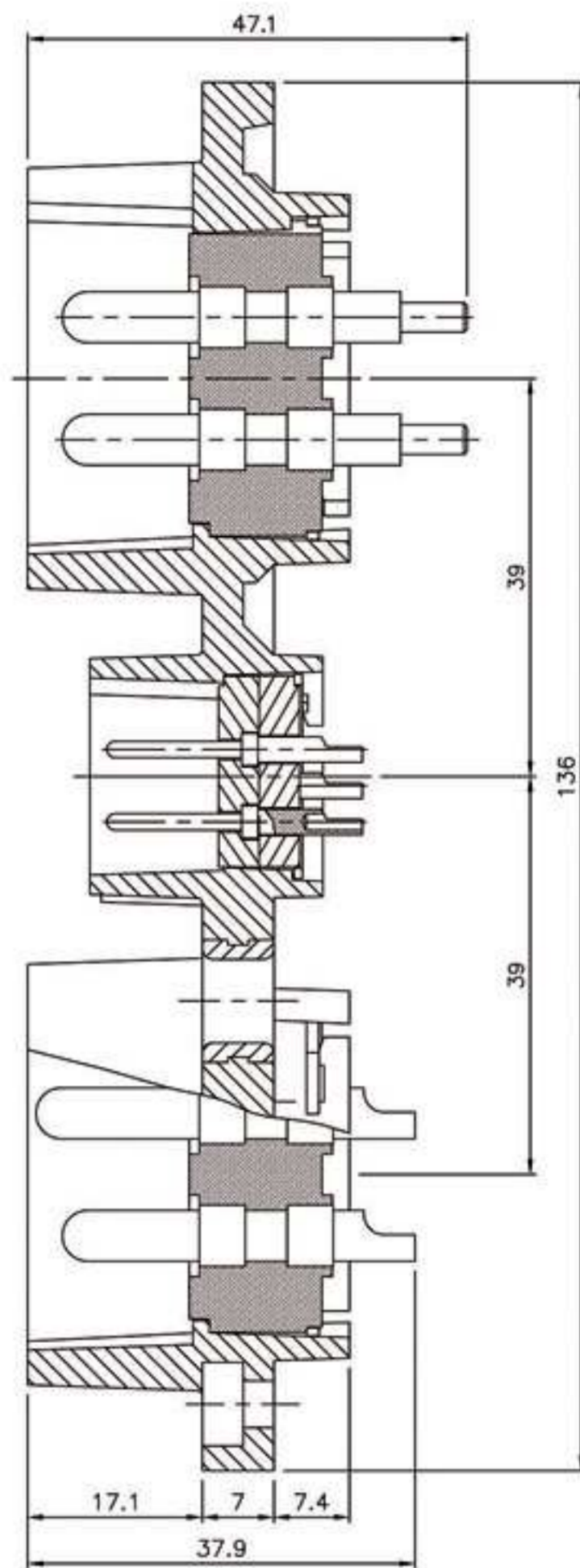
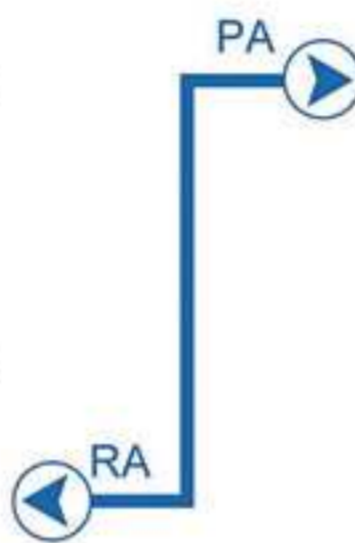
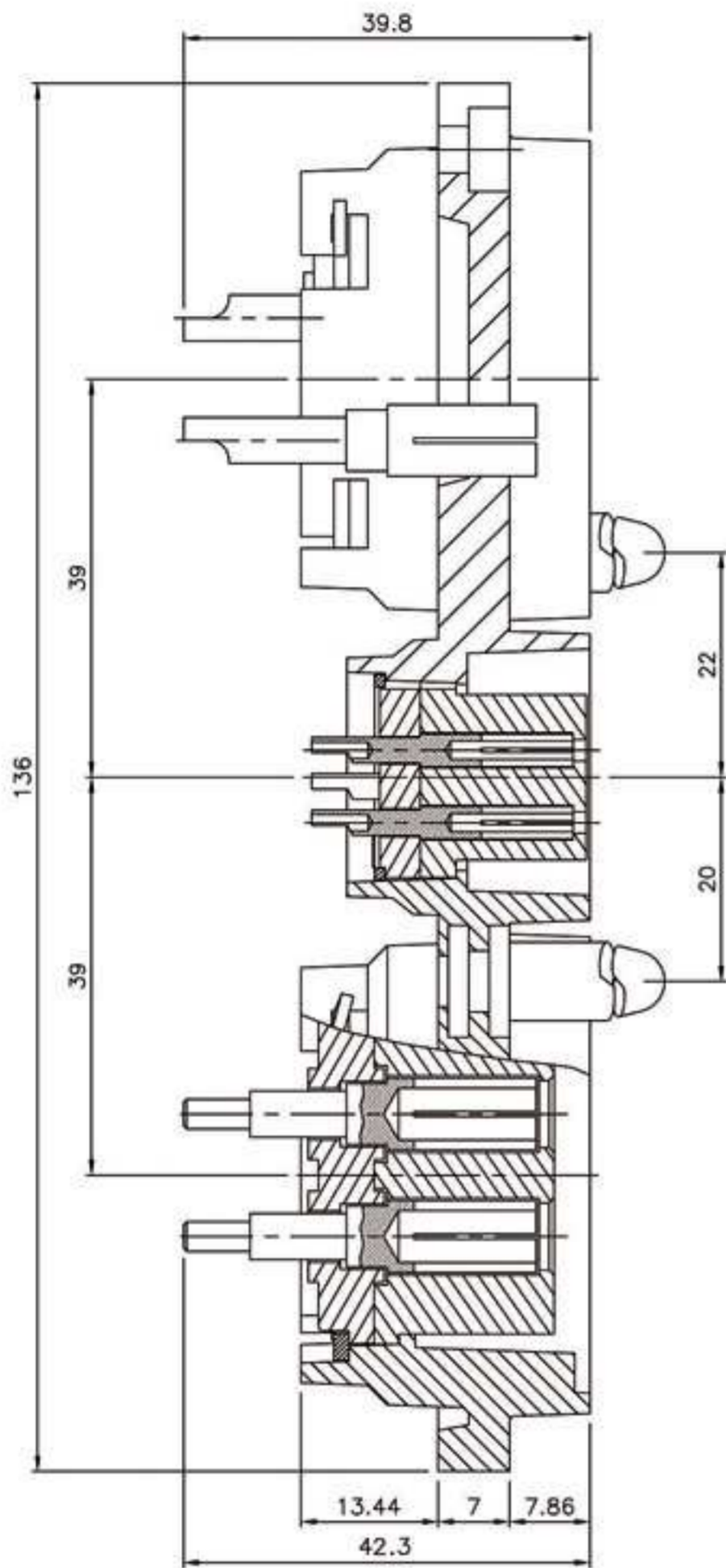

PAT PLTS-40 S-RA

PAT PLTS-40 S-PA

◆ No. of contacts	4				
Contacts Configuration					
Rated current / voltage	30A 250V				
Operating voltage limit (AC.V.rms)	500				
Withstanding voltage (AC.V.rms) 1 minute	2500				
Insulation resistance (MΩ MIN.) at DC 500V	2000				
Contact resistance (mΩ MAX.) at DC 1A	3				
Solder inter diameter	4				





www.plt.com.tw

E-mail: apexmail@plt.com.tw



— BUSINESS SCOPE —

- The 1st Production Dept. 第一製造部**
Connector · 軍用、防水、防爆、電機、醫療、工業連接器系列
Military / Waterproof / RF Coaxial / Industrial Series
- The 2nd Production Dept. 第二製造部**
Various Types of Molds · 精密模具
Customized Mold and Machinery Components Design & Manufacturing
- The 3rd Production Dept. 第三製造部**
Wire Assembly · 自動控制器材、配線接續部品
- The 4th Production Dept. 第四製造部**
Wireless Communication · 無線通信、天線、電子設備
Antenna / Transceiver / Peripheral Earphone Mic
- The 5th Production Dept. 第五製造部**
Precision Machine Manufacturing · 精密微調壓床、電動沖床、CNC自動電腦車銑複合機
CNC Turning and Milling Compound Lathe / Precision Arbor Press and Mechanical Press Manufacturing
- The 6th Production Dept. 第六製造部**
Medical Facilities for Senior Health Care · 醫療設備、健康照護
Wireless Remote Control Patient Care System / Medical Care On-Call System
- The 7th Production Dept. 第七製造部**
Channels of Distribution for Products Solution · 倉儲配銷、物流通路代理

Agent / 代理商

Diversified products for more information, please check our website
產品多元 · 網站查詢



Manufacturer / 國防部優質廠商

OEM / ODM Welcome

錫鋼精密科技股份有限公司
APEX PRECISION TECHNOLOGY CORP.



IPO 專業採購服務 · 整廠設備輸出
<http://rf.plt.com.tw>

總公司/總廠：24264 台灣新北市新莊區民安西路405號·Tel+886-2-2206-8899 (代表號)·Fax+886-2-2208-0559
Add No. 405, Min-an W. Rd., Sinjhuang District, New Taipei City 24264, Taiwan. R.O.C.

台中/大雅廠：42844 台灣台中市大雅區民生路3段191巷6號·Tel+886-4-2620-3939 · Fax+886-4-2620-3851
Add No.6, Ln. 191, Sec. 3, Minsheng Rd., Daya Dist., Taichung City 42844, Taiwan. R.O.C.

日本分公司
株式会社 PLT JAPAN

技術研發 · 台灣製造 / 進出口貿易
〒151-0053 東京都渋谷区代々木3丁目28番-1
28-1, Yoyogi 3-Chome, Shibuya-ku, Tokyo, Japan
TEL : +81-3-6276-8845(代) FAX : +81-3-6276-6645



ISO/TS 16949 全球汽車產業品質管理系統認證合格廠
ISO 9001-14001 國際環境品質管理系統保認證合格廠
ISO / TS 16949 CERTIFIED IN GLOBAL AUTOMOBILE INDUSTRY
ISO 14001 / 9001 INTERNATIONAL Q/C CERTIFIED